



2012 NFHS BASEBALL RULES BOOK

ROBERT B. GARDNER, Publisher
B. Elliot Hopkins, CAA, Editor
NFHS Publications

To maintain the sound traditions of this sport, encourage sportsmanship and minimize the inherent risk of injury, the National Federation of State High School Associations writes playing rules for varsity competition among student-athletes of high school age. High school coaches, officials and administrators who have knowledge and experience regarding this particular sport and age group volunteer their time to serve on the rules committee. Member associations of the NFHS independently make decisions regarding compliance with or modification of these playing rules for the student-athletes in their respective states.

NFHS rules are used by education-based and non-education-based organizations serving children of varying skill levels who are of high school age and younger. In order to make NFHS rules skill-level and age-level appropriate, the rules may be modified by any organization that chooses to use them. Except as may be specifically noted in this rules book, the NFHS makes no recommendation about the nature or extent of the modifications that may be appropriate for children who are younger or less skilled than high school varsity athletes.

Every individual using these rules is responsible for prudent judgment with respect to each contest, athlete and facility, and each athlete is responsible for exercising caution and good sportsmanship. These rules should be interpreted and applied so as to make reasonable accommodations for athletes, coaches and officials with disabilities.

© 2011, This rules book has been copyrighted by the National Federation of State High School Associations with the United States Copyright Office. No one may republish any material contained herein without the prior written consent of the NFHS. **Republication of all or any portion of this rules book on the Internet is expressly prohibited.**
Published by the NATIONAL FEDERATION OF STATE HIGH SCHOOL ASSOCIATIONS,
PO Box 690, Indianapolis, Indiana 46206; Phone: 317-972-6900, Fax: 317.822.5700,
www.nfhs.org. Cover photos courtesy of 20/20 Photographic, Mt. Pleasant, Michigan.

TABLE OF CONTENTS

Rule 1. Players, Field and Equipment	5
Rule 2. Playing Terms and Definitions	14
Rule 3. Substituting — Coaching — Bench and Field Conduct — Charged Conferences	25
Rule 4. Starting and Ending Game	31
Rule 5. Dead Ball — Suspension of Play	34
Dead Ball Tables	35-36
Rule 6. Pitching	38
Rule 7. Batting	42
Rule 8. Baserunning	45
Baserunning Awards Table	49
Rule 9. Scoring — Record Keeping	55
Rule 10. Umpiring	61
Suggested Speed - Up Rules	64
Suggested Double First Base Rules	65
Points of Emphasis	65-66
Rules by State Association Adoption	67
Major Rules Differences	68
Officials' Signal Chart	71
Index	93

2012 Baseball Rules Changes

- 1-3-2d** Clarified the allowable size and usage of the Batted Ball Coefficient of Restitution (BBCOR) mark.
- 1-3-5** Modified the restriction of intentionally altering the temperature of the bat.
- 1-5-8** Clarified how state associations may provide reasonable accommodations.
- 1-5-10** Clarified that the umpire is responsible for resolving any compliant equipment issues.
- 3-1-6** Clarified that any amount of blood found on a player's equipment or uniform requires immediate attention.
- 3-3-1g7** Modified the coaching decorum rule for post-game incidents.
- 3-3-1q** Clarified where a player's location should be during a fight or physical confrontation.
- 4-1-3a-b** Clarified the coach's responsibility for compliant equipment used in a game.
- 6-2-2e** Clarified the time allowance for relief pitchers warming up.
- Exception**
- 10-1-2** Clarified the game officials' administrative responsibilities.
- 10-2-3** Modified the officials' responsibility regarding pre-game equipment checks.
- Suggested Double First Base Rule**
Clarified the specific situation when the defensive player would be able to use either the orange or white base for registering an out.

Minor Editorial Rule Changes

- 8-4-1e** Editorial revision to align with 2011 rule change.
- Dead Ball and Delayed Dead Ball Table**
Awards or Penalties #2.

Points of Emphasis

(For a complete discussion of these points of emphasis, see pages 65-66.)

1. Good Sporting Behavior
2. Altering of Bats
3. Pace of the Game
4. Coach's Responsibility

Requests for baseball rule interpretations or explanations should be directed to the state association responsible for the high school baseball program in your state. The NFHS will assist in answering rules questions from state associations whenever called upon.

2011 NFHS BASEBALL RULES COMMITTEE



Larry White
Robbinsville, NJ
Chair - 2014



Jeremy Langner
NFHS Coaches — 2014
Waterloo, IA



Robert B. Gardner
Publisher
NFHS



B. Elliot Hopkins
Editor
NFHS



Ken Allan
NFHS Officials - 2013
Diamond Bar, CA



Anthony Azzara
Waterbury, CT
Section 1 - 2013

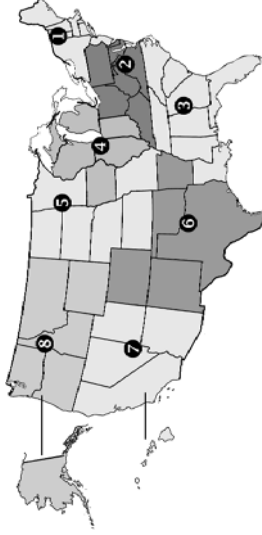

Peter Weber
Wilsonville, OR
Section 8 - 2014



Julian Tackett
Lexington, KY
Section 2 - 2011



Dennis Payne
Thomaston, GA
Section 3 - 2011



Phil Gardner
Indianapolis, IN
Section 4 - 2014



Brian Midthun
Enderlin, ND
Section 5 - 2013



Bert Borgmann
Aurora, CO
Section 6 - 2012



Rob Cluff
Salt Lake City, UT
Section 7 - 2012

Rule 1 *Players, Field and Equipment*

The NFHS does not perform scientific tests on any specific items of equipment to determine if the equipment poses undue risks to student-athletes, coaches, officials or spectators. Such determinations are the responsibility of equipment manufacturers.

SECTION 1 POSITIONS OF PLAYERS

ART. 1 . . . In high school baseball, each team is permitted seven turns at bat (see 4-2-2) during which it attempts to score runs by having its batters become base runners who advance to and touch first base, second base, third base and home plate. The team in the field attempts to end each turn at bat of the opponent by causing three of its batters or base runners to be out. Each of the two teams consists of at least nine players throughout the game (See Exception 4-4-1f), one of whom must be designated captain.

ART. 2 . . . The captain and head coach represent the team in communications with umpires. The captain's and head coach's duties shall include: 1) providing the umpire-in-chief with his team's lineup card which shall include the name, shirt number, position and batting order of each starting player, the name and shirt number of each eligible substitute should also be listed; and 2) informing all players as to special ground rules as announced by the umpire-in-chief. Lineups become official after they have been exchanged, verified and then accepted by the umpire during the pregame conference. The umpire shall not accept the lineup card until all substitutes are listed. There is no penalty assessed.

Diagram 1

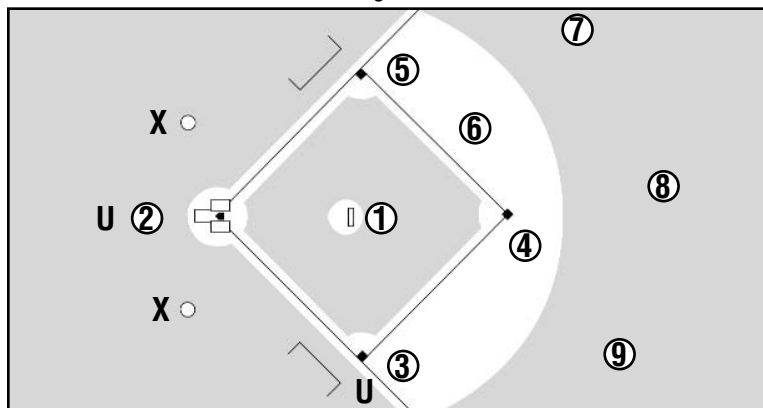

Key: 1—Pitcher; 2—Catcher; 3—1st Baseman; 4—2nd Baseman; 5—3rd Baseman; 6—Shortstop; 7—Left Fielder; 8—Center Fielder; 9—Right Fielder; U—Umpire; X—On-Deck Circle; Stippled Area—Grass

ART. 3 . . . A player is designated on the line up card and in the scorebook by name, shirt number, batting order position and fielding position. A customary arrangement of the fielders is shown in Diagram 1.

ART. 4 . . . At the time of the pitch, all fielders shall be on fair ground except the catcher who shall be in the catcher's box. A fielder is in fair ground when at least one foot is touching fair ground.

PENALTY: Illegal pitch. (2-18)

ART. 5 . . . A player may change to a different fielding position at any time except that a pitcher, after being listed as such on the official lineup card handed the umpire, cannot change until conditions in 3-1-1 and 2 are met. Changes should be reported to the umpire-in-chief and scorekeeper.

SECTION 2 THE FIELD

ART. 1 . . . A diamond (or infield) shall be a 90-foot square. When measuring the distance to first base and third base, measure from the apex of home plate to the back edge of the base. The outfield is the area between two foul lines formed by extending two sides of the diamond as in Diagram 2. The infield and outfield, including the boundary marks from home plate to first and third and their extended foul lines, are fair ground. All other area is foul ground.

ART. 2 . . . All lines on the playing field shall be marked with a material which is not injurious to the eyes or skin. All non-permanent lines should be white. Lime or caustic material of any kind is prohibited.

ART. 3 . . . The on-deck circle should be to the side and away from home plate, 37 feet if space allows. Neither team's players shall warm up in the other team's on-deck circle. The on-deck circle does not have to be occupied, but if a player wishes to warm up, he shall do so only in his team's on-deck circle, provided the on-deck circle is located safely away from home plate. (2-23)

ART. 4 . . . When the dugout area is temporarily extended, for any reason, it shall be extended toward the outfield on a line parallel to the foul line. The extension of the dugout area shall be equally applied for both teams.

ART. 5 . . . When constructing a new field for high school play, the distance from home plate to the nearest obstruction on fair ground should be at least 300 feet down the foul lines and at least 350 feet to center field. It is recommended that the line from home plate through the pitcher's plate to second base run east-northeast. This line, using a steel tape or a strong tape or a cord, must measure 127 feet, $3\frac{3}{8}$ inches from the rear tip of home plate to the middle of second base. The catcher's box, home plate, bases, coaches' boxes, batters' boxes, and three-foot running lane shall be as in Diagram 2. The recommended width of a foul line is $2\frac{1}{2}$ inches.

ART. 6 . . . On a sodded field, an unsodded area, commonly referred to as the "pitcher's mound," should have a radius of about nine feet centered $1\frac{1}{2}$ feet in front of the midpoint of the front edge of the pitcher's plate.

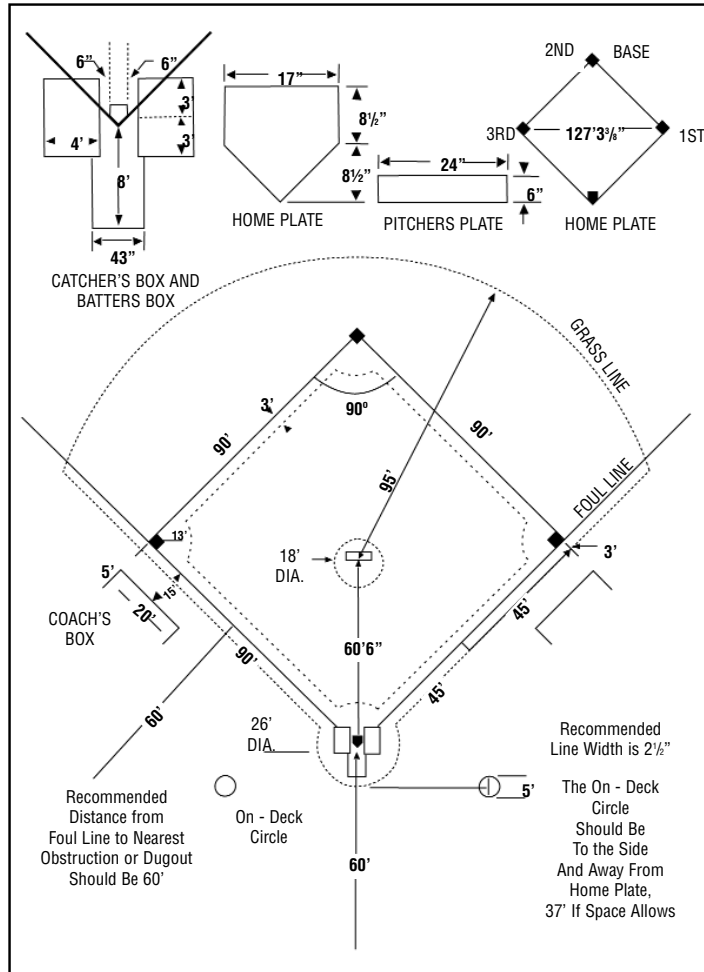
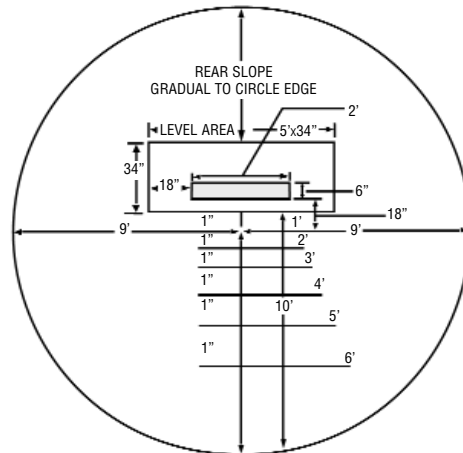

Diagram 2
OFFICIAL MEASUREMENTS . . . for laying out baseball field

SUGGESTED LAYOUT OF PITCHER'S MOUND, Diagram 3



The top of the pitcher's plate must be 10 inches above the top surface of home plate. Inside the circle, a pitcher's mound should be constructed according to the specifications shown in the diagram.

The degree of slope from a point 6 inches in front of the pitcher's plate to a point 6 feet toward home plate shall be one inch to one foot, and such degree of slope shall be uniform.

The pitching mound is an 18-foot diameter circle, the center of which is 59 feet from the back point of home plate.

Locate the front edge of the rubber 18 inches behind the center of the mound.

The front edge of the rubber to the back point of home plate is 60 feet, 6 inches.

The slope starts 6 inches from the front edge of the rubber.

The slope shall be 6 inches from the starting point, 6 inches in front of the rubber to a point 6 feet in front of the rubber.

The level area surrounding the rubber should be 6 inches in front of the rubber, 18 inches to each side and 22 inches to the rear of the rubber. The total level area is 5 feet x 34 inches.

ART. 7 . . . The pitcher's mound may consist in part of synthetic material that is commercially manufactured for that purpose. If a mound pad is composed of natural soil and synthetic material, the synthetic material must be securely attached to the ground and be installed at least flush or slightly below the surface of the ground. The mound area shall meet suggested height and slope specifica-

tions found in the Suggested Layout of the Pitcher's Mound (Diagram 3).

ART. 8 . . . Media shall be prohibited from being in live-ball area. If a designated media area is to be used, it shall be established before the game begins. The home team or game management shall designate a lined area for the media, which shall be considered dead-ball area.

ART. 9 . . . First, second and third bases shall be white bags, 15 inches square and 2 to 5 inches in thickness, and made of canvas filled with a soft material, or molded rubber or synthetic material, and shall be securely attached to the ground or an anchor system as in Diagram 2. Bases may have tapered edges and/or be designed to disengage from their anchor systems. By state association adoption, a double first base is permitted. The double first base shall be a white base and a colored base. The colored base shall be located in foul territory. (See Suggested Double First Base Rules, page 65)

ART. 10 . . . Home plate shall be a five-sided slab of whitened rubber or other suitable similar material. One edge is 17 inches long, two are 8½ inches and two are 12 inches. It shall be set in the ground so that the two 12-inch edges coincide with the diamond lines extending from home plate to first base and to third base, with the 17-inch edge facing the pitcher's plate.

ART. 11 . . . The pitcher's plate shall be a rectangular slab of whitened rubber or suitable material, 24 inches by 6 inches. It shall be set in the ground as shown in Diagram 2 so that the distance between the nearer edge of the pitcher's plate and the rear tip of home plate shall be 60 feet, 6 inches.

ART. 12 . . . Any game started on a nonregulation facility by mutual agreement of the opposing coaches shall not be protested for this reason.

SECTION 3 BATS, BALLS AND GLOVES

ART. 1 . . . The ball shall be a sphere formed by yarn wound around a small core of cork, rubber or similar material and covered with two strips of white horsehide or two strips of white cowhide tightly stitched together. It shall be 5 to 5¼ ounces in weight and have a circumference of 9 to 9¼ inches. The Coefficient of Restitution (COR) of baseballs shall not exceed .555. A minimum of three umpire-approved baseballs shall be provided to start the game. Unless otherwise mutually agreed upon, the home team has this responsibility. No less than two baseballs shall be used to complete a game.

The NFHS Authenticating Mark is required on all balls that will be used in high school competition.

A current list of NFHS authenticated products can



be found on the Web site: www.nfhs.org.

ART. 2 . . . The bat shall have the following characteristics and components.

- a. Each legal wood, aluminum or composite bat shall:
 1. Be one piece, multi-pieces and permanently assembled, or two pieces with interchangeable barrel construction.

2. Not have exposed rivets, pins, rough or sharp edges or any form of exterior fastener that would present a hazard.
3. Be free of rattles, dents, burrs, cracks and sharp edges. Bats that are broken, altered or that deface the ball are illegal. Materials inside the bat or treatments/devices used to alter the bat specifications and/or enhance performance are prohibited and render the bat illegal.
- b. Each legal wood, aluminum or composite bat shall have the following components:
 1. Knob. The bat knob shall protrude from the handle. The knob may be molded, lathed, welded or permanently fastened. Devices, attachments or wrappings are permitted except those that cause the knob to become flush with the handle. A one-piece rubber knob and bat grip combination is illegal.
 2. Handle. The bat handle is the area of the bat that begins at, but does not include, the knob and ends where the taper begins.
 3. Barrel. The barrel is the area intended for contact with the pitch. The barrel shall be round, cylindrically symmetric and smooth. The barrel may be aluminum, wood or composite (made of two or more materials). The type of bat (wood, aluminum or composite) shall be determined by the composition of the barrel.
 4. Taper. The taper is an optional transition area which connects the narrower handle to the wider barrel portion of the bat. Its length and material may vary but may not extend more than 18 inches from the base of the knob.
 5. End Cap. The end cap is made of rubber, vinyl, plastic or other approved material. It shall be firmly secured and permanently affixed to the end of the bat so that it cannot be removed by anyone other than the manufacturer, without damaging or destroying it. By definition, a one-piece construction bat does not have an end cap.
- c. Each bat not made of a single piece of wood shall:
 1. Have a safety grip made of cork, tape (no smooth, plastic tape) or commercially manufactured composition material. The grip must extend a minimum of 10 inches, but not more than 18 inches, from the base of the knob. Slippery tape or similar material shall be prohibited. Resin, pine tar or any drying agent to enhance the hold are permitted only on the grip. Molded grips are illegal.
 2. Be $2\frac{5}{8}$ " or less in diameter at thickest part and 36 inches or less in length.
 3. Not weigh, numerically, more than three ounces less than the length of the bat (e.g., a 33-inch-long bat cannot be less than 30 ounces).
- d. Beginning January 1, 2012, all bats not made of a single piece of wood shall meet the Batted Ball Coefficient of Restitution (BBCOR) performance standard, and such bats shall be labeled with a silkscreen or other permanent certification mark. No BBCOR label, sticker or decal will be accepted on any non-wood bat. The certification mark shall be rectangular, a minimum of one inch on each side and located on the barrel of the bat in any contrasting color to read: "BBCOR .50."

NOTE: NFHS staff will work with appropriate parties to research and develop a baseball bat tamper-evident protocol for non-wood bats and present the recommendations to the NFHS Baseball Rules Committee for its consideration at the June 3-5, 2012, rules committee meeting, with the goal for implementation to be for non-wood bats manufactured after January 1, 2015.

ART. 3 . . . A bat made of a single piece of wood may be roughened or wound with tape not more than 18 inches from the handle end of the bat. No foreign substance may be added to the surface of the bat beyond 18 inches from the end of the handle. Each bat made of a single piece of wood shall be:

- a. 2¾ inches or less in diameter at the thickest part
- b. 36 inches or less in length

ART. 4 . . . Only bats may be used in warming up (including weighted bats used for this purpose) at any location. Only bats and items designed to remain part of the bat, such as weighted bats, batting donuts, and wind-resistant devices are legal at any location.

ART. 5 . . . Bats that are altered from the manufacturer's original design and production, or that do not meet the rule specifications, are illegal (See 7-4-1a). No artificial or intentional means shall be used to control the temperature of the bat. No foreign substance may be inserted into the bat. Bats that are broken, cracked or dented or that deface the ball, i.e., tear the ball, shall be removed without penalty. A bat that continually discolors the ball may be removed from the game with no penalty at the discretion of the umpire.

ART. 6 . . . Gloves/mitts made of leather shall be worn by all fielders and not be altered to create an adhesive, sticky, and/or tacky surface. The glove/mitt worn by the catcher may be any size. The glove/mitt worn by the pitcher that includes the colors white and/or gray shall be removed from the game upon discovery by either team and/or umpire. The glove/mitt worn by all fielders except the catcher shall conform to the following maximum specifications (found in Diagram 4):

- a. Height (measured from the bottom edge or heel straight up across the center of the palm to a line even with the highest point of the glove/mitt): 14 inches
- b. Width of palm (measured from the bottom edge of the webbing farthest from the thumb in a horizontal line to the outside of the little finger edge of the glove/mitt): 8 inches
- c. Webbing (measured across the top end or along any line parallel to the top): 5¾ inches

ART. 7 . . . Loose equipment, such as gloves, bats, helmets or catcher's gear, of either team may not be on or near the field.

PENALTY: If loose equipment interferes with play, the umpire may call an out(s), award bases or return runners, based on his judgment and the circumstances concerning the play.

Diagram 4

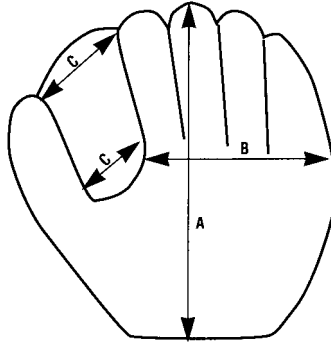

SECTION 4 UNIFORMS

ART. 1 . . . Uniforms of all team members should be of the same color and style. Caps and shoes are required equipment (no track spikes allowed). When a player is required to wear a head protector, it replaces the cap as mandatory equipment.

ART. 2 . . . For individual players, uniform sleeve lengths may vary. However, sleeves of each individual player shall be approximately the same length and shall not be ragged, frayed or slit. If the pitcher's undershirt sleeves are exposed, they shall not be white or gray. A pitcher shall not wear any item on his hands, wrists or arms which may be distracting to the batter. A pitcher shall not wear white or gray exposed undershirt sleeves or any white or gray sleeve that extends below the elbow. A vest and coordinating shirt that is worn underneath is viewed as a type of uniform top.

ART. 3 . . . A uniform shall not have any dangerous or reflective buttons or ornaments. Each player shall be numbered on the back of his shirt with a plain number of solid color contrasting with the color of the shirt. This number shall be a plain Arabic style and shall be at least eight inches high, and no players on the same team shall wear identical numbers. A number may have a border of not more than one-quarter inch in width.

ART. 4 . . . The school's official uniform (including uniform pants, jersey, visible undergarments, socks, stockings, caps and headwear) may bear only a visible single manufacturer's logo (partial or whole) or trademark. A manufacturer's logo/trademark shall not exceed $2\frac{1}{4}$ square inches with no dimension exceeding $2\frac{1}{4}$ inches. No more than one manufacturer's logo/trademark or reference shall be permitted on the outside of each item. (The same restriction shall apply to either the manufacturer's logo/trademark or reference.) One American flag 2 inches x 3 inches may be worn on each item of uniform apparel.

By state association adoption, to allow for special occasions, commemorative or memorial patches, that will be uniformly placed, not to exceed 4 square inches, to be worn on jerseys in an appropriate and dignified manner without compromising the integrity of the uniform.

SECTION 5 PLAYER EQUIPMENT

ART. 1 . . . It is mandatory for on-deck batters, batters, runners, retired runners, players/students in the coaches boxes as well as non-adult bat/ball shaggers to wear a batting helmet that meets the NOCSAE standard. The batting helmet shall have extended ear flaps that cover both ears and temples and also display the NOCSAE stamp and the exterior warning statement. The warning statement may be affixed to the helmet in sticker form, or it may be embossed at the time of manufacture. A violation by a non-adult bat/ball shagger shall result in a warning to the coach of the team and the individual. A subsequent violation may result in the individual not being allowed on the field.

PENALTY: When an umpire observes anyone who is required to wear a batting helmet deliberately remove his batting helmet while in live-ball territory and the ball is live (non-adult ball/bat shaggers required to wear batting helmet in live-ball area even if ball is dead), the umpire shall issue a warning to the coach of the involved team, unless the ball becomes dead without being touched by a fielder or, after being touched, goes directly to dead-ball area. A subsequent violation of the rule shall result in ejection.

ART. 2 . . . A face mask/guard may be attached to batting helmets at the time of manufacture. All face mask/guards shall meet the NOCSAE standard. A face mask/guard specifically designed for a particular helmet model may be attached after manufacture, provided that procedure is approved by the manufacturer and meets the NOCSAE standard.

ART. 3 . . . The catcher shall wear, in addition to a head protector, a mask with a throat protector, body protector, protective cup (male only), and baseball protective shin guards.

ART. 4 . . . The catcher's helmet and mask combination shall meet the NOCSAE standard. Any helmet or helmet and mask combination shall have full ear protection (dual ear flaps). A throat protector, which is either a part of or attached to the catcher's mask, is mandatory. A throat protector shall adequately cover the throat. The commercially manufactured catcher's head, face and throat protection may be a one-piece or multi-piece design. While in a crouch position, any non-adult warming up a pitcher at any location shall wear a head protector, a mask with a throat protector and a protective cup (male only).

PENALTY: Failure by a player to wear proper equipment after being so ordered by the umpire, shall result in ejection.



ART. 5 . . . Defensive players are permitted to wear face/head protection in the field. If a pitcher or any defensive player wears face/head protection, its outer covering shall have a non-glare surface.

ART. 6 . . . Defective equipment must be repaired or replaced immediately.

ART. 7 . . . If a ball is touched with an illegal glove or mitt, that is discovered by the umpire, the coach or captain of the team at bat has the choice of taking the result of the play or having the award (8-3-3a, b, c) for use of an illegal glove or mitt. The illegal glove or mitt must be replaced immediately. A foul fly caught with an illegal glove/mitt shall be nullified and treated as a foul ball, unless the team at bat elects to take the result of the play.

ART. 8 . . . Hard and unyielding items (guards, casts, braces, splints, etc.) must be padded with a closed-cell, slow-recovery foam padding no less than 1/2" thick. Knee and ankle braces which are unaltered from the manufacturer's original design/production do not require any additional padding. Each state association may, in keeping with applicable laws, authorize exceptions to NFHS playing rules to provide reasonable accommodations to individual participants with disabilities and/or special needs, as well as those individuals with unique and extenuating circumstances. The accommodations should not fundamentally alter the sport, allow an otherwise illegal piece of equipment, create risk to the athlete/others or place opponents at a disadvantage.

ART. 9 . . . Any player equipment judged by the umpire to be unreasonably dangerous is illegal.

ART. 10 . . . Any questions regarding legality of a player's equipment shall be resolved by the umpire-in-chief.

ART. 11 . . . Non-traditional playing equipment must be reviewed by the NFHS Baseball Rules Committee before it will be permitted to be used.

ART. 12 . . . Jewelry shall not be worn (See 3-3-1d) except for religious or medical medals. A religious medal must be taped and worn under the uniform. A medical alert must be taped and may be visible.

Rule 2 *Playing Terms and Definitions*

SECTION 1 ABBREVIATIONS

ART. 1 . . . For brevity in the play rulings, the home team is H and the visiting team V.

ART. 2 . . . Players of the team at bat are B1, B2, etc. The player who bats first in his half of an inning is designated B1. The second player to bat is B2, etc. Substitutes are S1, S2, etc. Runners are R1, R2, or R3, and R1 is the runner who has advanced farthest.

ART. 3 . . . Fielding players are F1, F2, etc., in accordance with Diagram 1.

SECTION 2 AWARDED BASES

When bases are awarded, it is the responsibility of the runner to legally touch those bases. In actuality, it is the right to advance without a play being made that is awarded.

SECTION 3 BALK

A balk is an illegal act committed by the pitcher with a runner(s) on base which entitles each runner to advance one base.

SECTION 4 BALL, BASE ON BALLS, INTENTIONAL BASE ON BALLS

ART. 1 . . . The ball is one of the playing implements (See 1-3-1). The term is also used to designate a pitch which is not touched by the bat and is not a strike as in 7-2-1 and 7-2-2.

ART. 2 . . . A base on balls is an award of first base (often referred to as a "walk") if a batter receives four such balls. The batter must go immediately to first base before time-out is called.

ART. 3 . . . An intentional base on balls may be given by the defensive team by having its catcher or coach request the umpire to award the batter first base. This may be done before pitching to the batter or on any ball and strike count. The ball shall be declared dead before making the award.

SECTION 5 FAIR BALL/BASE HIT

ART. 1 . . . A fair ball is a batted ball which:

- a. settles on fair territory between home and third base or between home and first base; or
- b. contacts fair ground on or beyond an imaginary line between first and third base; or
- c. is on or over fair ground when bounding to the outfield past first or third base; or
- d. first falls on fair ground on or beyond first or third base; or
- e. touches first, second or third base; or
- f. while on or over fair territory, touches the person of an umpire or player, their clothing or equipment; or
- g. while over fair ground passes out of the playing field in flight.
 1. A fly ball or line drive, which passes over or inside first or third base in flight and curves to foul ground beyond such base, is not a fair hit; but a hit which goes over or through the fence is a fair hit if it is over fair ground when it leaves the field.

ART. 2 . . . A base hit (also called a safe hit or single) is one which enables the batter to advance to first base without being put out (9-3-2).

ART. 3 . . . An extra base hit is one which enables the batter to advance to first

base and then to one or more succeeding bases (9-3-3). A two-base hit (double), three-base hit (triple) or home run enables him to reach second, third or home base, respectively.

SECTION 6 BATTED BALL

ART. 1 . . . A batted or thrown ball is in flight until it has touched the ground or some object other than a fielder.

ART. 2 . . . A fly ball is a batted ball which rises an appreciable height above the ground.

ART. 3 . . . A line drive is a batted ball which travels parallel, or nearly so, with the ground through most of its flight.

ART. 4 . . . A ground ball is one which is neither a fly nor a line drive.

SECTION 7 BATTER, BATTER'S BOX, BATTER-RUNNER

ART. 1 . . . The batter is the player of the team at bat who is entitled to occupy either of the two batters' boxes as shown in Diagram 2.

ART. 2 . . . The batter's box is the 4 foot x 6 foot area in which the batter shall stand when batting. The lines are part of the box. (See Official Measurements in Diagram 2)

ART. 3 . . . A batter-runner is a player who has finished a time at bat until he is put out or until playing action ends.

SECTION 8 BUNT

A bunt is a fair ball in which the batter does not swing to hit the ball, but holds the bat in the path of the ball to tap it slowly to the infield. If an attempt to bunt is a foul ball, it is treated the same as any other foul ball, except that if the attempt is by a batter who has two strikes, such batter is out as in 7-4-1e.

SECTION 9 CATCH, CATCHER, CATCHER'S BOX

ART. 1 . . . A catch is the act of a fielder in getting secure possession in his hand or glove of a live ball in flight and firmly holding it, provided he does not use his cap, protector, mask, pocket or other part of his uniform to trap the ball. The catch of a fly ball by a fielder is not completed until the continuing action of the catch is completed. A fielder who catches a ball and then runs into a wall or another player and drops the ball has not made a catch. A fielder, at full speed, who catches a ball and whose initial momentum carries him several more yards after which the ball drops from his glove has not made a catch. When the fielder, by his action of stopping, removing the ball from his glove, etc., signifies the initial action is completed and then drops the ball, will be judged to have made the catch. The same definition of a catch would apply when making a double play. It is considered a catch if a fielder catches a fair or foul ball and then steps or falls into a bench, dugout, stand, bleacher or over any boundary or barrier, such as a

fence, rope, chalk line, or a pregame determined imaginary boundary line from the field of play. Falling into does not include merely running against such object. (See 2-24-4 for fielder juggling ball and 8-4-1c for intentionally dropped ball; 2-16-2 and 5-1-1d for ball striking catcher before touching his glove.) It is not a catch when a fielder touches a batted ball in flight which then contacts a member of the offensive team or an umpire and is then caught by a defensive player.

NOTE: When a batted ball or a pitch is involved, the above definition of a catch applies.

For any other thrown ball, the term is used loosely to also apply to a pick-up or to the trapping of a low throw which has touched the ground. A fielder may have the ball in his grasp even though it is touching the ground while in his glove.

ART. 2 . . . The catcher is the player to whom the pitcher throws when delivering the ball to the batter.

ART. 3 . . . The catcher's box is an area 43 inches by 8 feet. See official measurements in Diagram 2.

SECTION 10 CONFERENCES

ART. 1 . . . A charged conference is a meeting which involves the coach or his non-playing representative and a player or players of the team. Defensive — See 3-4-1; Offensive — See 3-4-2.

ART. 2 . . . A pregame conference is a meeting involving the umpires, both head coaches and team captains (if available) near home plate. The meeting should begin approximately five minutes prior to the game. The purpose of the pregame conference is to exchange and check each team's lineup cards and to discuss ground rules. Umpires also shall ask the head coaches of the two opposing teams if their players are legally and properly equipped. In addition, the expectation of good sporting behavior is shared with both teams and representatives (4-1-3a). Both teams shall remain in their dugout (bench) or bullpen area until this meeting has concluded.

SECTION 11 DEAD BALL

The ball becomes dead when acts listed in 5-1 occur or play is suspended as in 5-2-1. See table in Rule 5.

SECTION 12 ERROR

ART. 1 . . . An error is a misplay by a fielder or a team (9-5-5), which is recorded in the error column of the player's or team's record.

ART. 2 . . . Other misplays that are not recorded in the error column but are included in the game summary include a balk (6-2-4), wild pitch (9-6-1), batter hit by pitched ball (8-1-1d) and passed ball (9-6-1).

SECTION 13 FIELDER

ART. 1 . . . A fielder is any one of the nine players of the defensive team.

ART. 2 . . . The players who play left field, right field and center field are outfielders.

ART. 3 . . . The others are infielders.

ART. 4 . . . The pitcher and catcher are the battery.

ART. 5 . . . In the play rulings, a fielder is referred to as F1, F2, etc. Refer to Diagram 1.

SECTION 14 FIELDER'S CHOICE

ART. 1 . . . A fielder's choice is the act of a fielder with a live ball, who elects to throw for an attempted putout or to retire unassisted any runner or batter-runner, thus permitting the advance of another runner(s). The scorer decides whether the batter is credited with a safe hit or an extra base hit in accordance with 9-2-2, 9-3-3. Scorers use the term in the following ways:

- a. to indicate the advance of the batter-runner who takes one or more bases when the fielder who handles his batted ball plays on a preceding runner;
- b. to indicate the advance of a runner (other than by stolen base or error) while a fielder is trying to put out another runner; and
- c. to indicate the advance of a runner due to the defensive team's refusal to play on him (an undefended steal).

SECTION 15 FORFEITED GAME

A forfeited game is one awarded to the opponent of the offending team (4-4).

SECTION 16 FOUL, FOUL TIP

ART. 1 . . . A foul is a batted ball:

- a. which settles on foul territory between home and first base or between home and third base; or
- b. that bounds past first or third base on or over foul territory; or
- c. that first falls on foul territory beyond first or third base; or
- d. that, while on or over foul territory, touches the person of an umpire or a player or any object foreign to the natural ground; or
- e. that touches the ground after inadvertently being declared foul by an umpire.

ART. 2 . . . A foul tip is a batted ball that goes directly to the catcher's hands and is legally caught by the catcher. It is a strike and the ball is in play.

SECTION 17 GAME, CALLED GAME, SUSPENDED GAME

ART. 1 . . . A regulation interscholastic game is seven innings (turns at bat) for each team unless shortened as in 4-2-2 and 4-2-3, or unless extra innings are necessary to break a tie score.

ART. 2 . . . A called game is one which is ended by order of the umpire in accordance with 4-3.

ART. 3 . . . A suspended game is a called game to be completed at a later time.

SECTION 18 ILLEGAL PITCH

An illegal pitch is an illegal act committed by the pitcher with no runner on base, which results in a ball being awarded the batter. When an illegal pitch occurs with a runner, or runners, on base, it is ruled a balk.

SECTION 19 INFIELD FLY

An infield fly is a fair fly (not including a line drive nor an attempted bunt) which can be caught by an infielder with ordinary effort, (rule does not preclude outfielders from being allowed to attempt to make the catch) and provided the hit is made before two are out and at a time when first and second bases or all bases are occupied.

When it seems apparent that a batted ball will be an infield fly, the umpire immediately announces it for the benefit of the runners. If the ball is near a baseline, the umpire shall declare, "Infield fly, if fair." (See 8-4-1j for batter being out and right of base runner to advance after retouching his base.)

SECTION 20 INNINGS

ART. 1 . . . An inning is that portion of the game which includes a turn at bat for each team.

ART. 2 . . . A half-inning is the interval during which one team is on offense (batting) and the other is on defense (fielding). A half-inning ends when there is a third out or when, in the last inning, the winning run is scored. In either case, if there is a delayed out declared by the umpire for a baserunning infraction, a possible fourth out may be recognized (9-1-1d, e).

ART. 3 . . . An extra inning is one which extends the game in an attempt to break the tie score.

SECTION 21 INTERFERENCE — OFFENSIVE, UMPIRE, SPECTATOR

ART. 1 . . . Offensive interference is an act (physical or verbal) by the team at bat:

- a. which interferes with, obstructs, impedes, hinders or confuses any fielder attempting to make a play; or
- b. when a runner creates malicious contact with any fielder, with or without the ball, in or out of the baseline; or
- c. a coach physically assists a runner during playing action.

ART. 2 . . . It is umpire interference when he inadvertently moves so as to hinder a catcher's attempt to throw, or when a fair ball touches an umpire as in 5-1-1f, or thrown ball as in 5-1-1g.

ART. 3 . . . Spectator interference is an act by a spectator which impedes the progress of the game.

SECTION 22 OBSTRUCTION AND FAKE TAG

ART. 1 . . . Obstruction is an act (intentional or unintentional, as well as physical or verbal) by a fielder, any member of the defensive team or its team personnel that hinders a runner or changes the pattern of play as in 5-1-3 and 8-3-2; or when a catcher or fielder hinders a batter as in 5-1-2b, 8-1-1e, 8-3-1c and 8-3-2. When obstruction occurs, the ball becomes dead at the end of playing action and the umpire has authority to determine which base or bases shall be awarded the runners according to the rule violated (Exceptions 8-4-2c, 8-4-2d).

ART. 2 . . . A fake tag is an act by a defensive player without the ball that simulates a tag. A fake tag is considered obstruction.

ART. 3 . . . The fielder without possession of the ball denies access to the base the runner is attempting to achieve.

SECTION 23 ON-DECK CIRCLE

An on-deck circle for each team is a circle five feet in diameter located 37 feet to the side and away from home plate if space permits. Otherwise, it should be a safe distance to the side and away from home plate (See Diagram 2).

SECTION 24 OUT: FORCE-OUT, PUTOUT, STRIKEOUT, TAG OUT, THROW-OUT

ART. 1 . . . A force-out is a putout during which a runner who is being forced to advance is tagged out, or is put out by a fielder who holds the ball while touching the base toward which the forced runner is advancing (9-1-1 for special case.)

ART. 2 . . . A putout is the act of a fielder in retiring a batter or runner. For putouts credited to the catcher and to other fielders, see 9-5-2. An "out" is one of the three required retirements of players of the team at bat.

ART. 3 . . . A strikeout is the result of the pitcher getting a third strike charged to a batter. This usually results in the batter being out, but does not so result if the third strike is not caught and the batter-runner legally reaches first base.

ART. 4 . . . A tag out is the put out of a runner, including the batter-runner, who is not in contact with his base when touched with a live ball, or with the glove or hand when the live ball is held securely therein by a fielder. The ball is not considered as having been securely held if it is juggled or dropped after the touching, unless the runner deliberately knocks the ball from the hand of the fielder (8-4-2h2).

ART. 5 . . . A throw out is a putout caused by a throw to first base to retire a batter-runner, or to any other base to which a runner is forced or is required to retouch.

SECTION 25 OVERRUNNING OR OVERSLIDING

ART. 1 . . . Overrunning or oversliding is the act of a runner who, after touching the base to which he is advancing, allows his momentum to carry him past

the base so that he loses contact with it.

For the right to overrun first base, see 8-2-6. For cases where a runner is not credited with a stolen base or a batter with an extra base hit, see 2-5-3, 9-3-3, and 9-4-1. If a force is involved, 2-29-3 states that touching a base ends a force.

SECTION 26 PASSED BALL

A passed ball is a pitch which the catcher fails to stop or control when he should have been able to do so with ordinary effort, and which enables a runner including the batter-runner to advance.

SECTION 27 PENALTY

ART. 1 . . . A penalty is the action taken by the umpire against a player, coach or team for a rule infraction. Penalties include:

- a. restricting the coach to the dugout;
- b. ejecting an offending player or coach;
- c. declaring a batter or runner out;
- d. awarding a base to a batter or runner;
- e. awarding a ball to a batter (for an illegal pitch when there is no runner or for delay by the pitcher);
- f. charging a batter with a strike (for delay);
- g. forfeiting a game; or
- h. removing nonplayers from the bench or field.

SECTION 28 PITCHER, PITCH, PIVOT FOOT

ART. 1 . . . The pitcher is the player who is designated in the lineup as being responsible for delivering (pitching) the ball to the batter.

ART. 2 . . . A live ball delivered to the batter is a pitch. The term implies a legally delivered ball unless otherwise stated. When a pitcher commits a balk and completes his delivery to the batter, or delivers an illegal pitch, it is not considered a pitch, because the ball became dead at the time of the infraction.

ART. 3 . . . Time of the pitch is when the pitcher has committed himself to delivering the pitch to the batter. For the windup position, the "time of the pitch" occurs when the pitcher, (a) first starts any movement of his arm(s) or leg(s) after stepping onto the pitcher's plate with his hands already together in front of his body; (b) with both hands at his side, first starts any movement with both arms or leg(s) prior to the pitch; (c) with either hand in front of the body and the other hand at his side, after bringing his hands together, first starts any movement of his arm(s) or leg(s) prior to the pitch. For the set position, the "time of the pitch" occurs the instant the pitcher, after coming to a complete and discernible stop, starts any movement with arm(s) and/or leg(s) that commits him to pitch.

ART. 4 . . . A pitch ends when the pitched ball:

- a. is secured by the catcher,

- b. comes to rest,
- c. goes out of play,
- d. becomes dead,
- e. or the batter hits the ball (other than a foul tip).

ART. 5 . . . A feint is a movement which simulates the start of a pitch or a throw to a base and which is used in an attempt to deceive a runner.

ART. 6 . . . The pitcher's pivot foot is that foot with which the pitcher contacts the pitcher's plate when he delivers the ball. For example, the pivot foot is the left foot for a left-handed pitcher (6-1-1).

SECTION 29 PLAY, DOUBLE PLAY, FORCE PLAY, PLAY RULING, SQUEEZE PLAY

ART. 1 . . . "Play" is the order given by the umpire when it is time for the game to begin, or to be resumed after having been suspended when he called "time." The term is also used to denote a unit of action which begins when a pitcher has the ball in his possession in pitching position and ends when ball becomes dead or pitcher again holds the ball while in pitching position.

ART. 2 . . . A double play is continuous activity which results in two putouts during a play as defined in Article 1.

ART. 3 . . . A force play is a play in which a runner (or two or three runners) loses his right to the base he occupies and is forced to advance because the batter becomes a batter-runner. For a given runner, a force play ends as soon as he touches the next base or a following runner is put out at a previous base. When a runner advances beyond a base to which he is forced without touching it, the force play remains. Also, a force situation is reinstated when a runner retreats past the base to which he was forced to advance.

ART. 4 . . . A play ruling is a statement of a play situation and the correct ruling. It is considered an integral part of the rules and applies to analogous situations.

ART. 5 . . . A squeeze play is one in which a runner advances toward home plate from third base as the ball is being pitched, and during which the batter bunts to permit the runner to score.

ART. 6 . . . A defensive appeal of a runner failing to touch a base or tag up is not a play.

SECTION 30 RUN, RUNNERS, RETIRED RUNNERS

ART. 1 . . . A run is the score made by a runner who legally advances to and touches home plate (9-1).

ART. 2 . . . A runner is a player of the team at bat who has finished his time at bat and has not yet been put out. The term includes the batter-runner and also any runner who occupies a base.

ART. 3 . . . A retired runner is a player of the team at bat who has been put out, or who has scored and is still in live-ball area.

SECTION 31 SACRIFICE

A sacrifice is a bunt which enables any runner to advance, or a fly ball (sacrifice fly) which enables a runner to score. In either case, the result is the batter-runner being put out before he reaches first base, or would have resulted in his being put out if the batted ball had been fielded without error, and provided two were not out when the ball was hit. A sacrifice is not listed as a time-at-bat (9-3-4).

SECTION 32 SLIDE

ART. 1 . . . A legal slide can be either feet first or head first. If a runner slides feet first, at least one leg and buttock shall be on the ground. If a runner slides, he must slide within reach of the base with either a hand or a foot. A runner may slide or run in a direction away from the fielder to avoid making contact or altering the play of the fielder (8-4-2b).

ART. 2 . . . A slide is illegal if:

- a. the runner uses a rolling, cross-body or pop-up slide into the fielder, or
- b. the runner's raised leg is higher than the fielder's knee when the fielder is in a standing position, or
- c. the runner goes beyond the base and then makes contact with or alters the play of the fielder, or
- d. the runner slashes or kicks the fielder with either leg, or
- e. the runner tries to injure the fielder, or
- f. the runner, on a force play, does not slide on the ground and in a direct line between the two bases.

SECTION 33 SPEED-UP RULES

Rule modifications to speed up the game may be adopted by state associations (see page 64).

SECTION 34 STOLEN BASE, DOUBLE STEAL, TRIPLE STEAL

ART. 1 . . . A stolen base is an advance of a runner to the next base without the aid of a base hit, a putout or a fielding (including battery) error (9-4).

ART. 2 . . . A double steal is two runners advancing on such a play.

ART. 3 . . . A triple steal is three runners advancing on such a play.

SECTION 35 STRIKE ZONE

The strike zone is that space over home plate, the top of which is halfway between the batter's shoulders and the waistline, and the bottom being the knees, when he assumes his natural batting stance. The height of the strike zone is determined by the batter's normal batting stance. If he crouches or leans over to make the shoulder line lower, the umpire determines height by what would be the batter's normal stance.

SECTION 36 SUBSTITUTIONS

ART. 1 . . . A substitute is a player who is eligible to replace another player already in the lineup.

ART. 2 . . . An unreported substitute is a player who, by rule, can be in the game but has entered without reporting.

ART. 3 . . . An illegal substitute is:

- a. a player who enters or re-enters the game without eligibility to do so, or
- b. a player who re-enters the game in the wrong position in the batting order, or
- c. a player who enters the game on defense while the player for whom he is batting is on defense, or
- d. when the player for whom the DH is batting enters the game as a batter or runner in a different position in the batting order, or
- e. a player who violates the courtesy runner rule.

SECTION 37 THROW

A throw is the act of voluntarily losing possession through having the ball leave the hand for a purpose other than a pitch. It may result in the ball being bounced, handed, rolled, tossed or thrown.

SECTION 38 TIME

“Time” is the command of the umpire to suspend play. The ball becomes dead when it is given (5-2-1). The term is also used in recording the length of the game.

SECTION 39 TIME AT BAT

Time at bat is the period beginning when a batter first enters the batter’s box and continuing until he is put out or becomes a runner. A batter is not charged in the records with a time at bat when he makes a sacrifice hit, is hit by a pitched ball, is awarded a base on balls, is replaced before being charged with two strikes, is replaced after being charged with two strikes and the substitute does not strike out, or when he advances to first base because of obstruction by a fielder.

SECTION 40 TOUCHING BALL, BASE OR RUNNER

Touching is contact with, and there is no distinction between the act of touching or by being touched. The term applies to contact with any part of the person or his clothing if the clothing is reasonably well fitted. This includes:

- a. a pitched ball touching a batter, or
- b. a batted ball touching a batter or any runner, or
- c. the catcher touching the bat, or
- d. a player touching a base, or
- e. a ball touching a player or nonplayer.

NOTE: For failure to touch home plate, see 8-2-5 Penalty; for retouching base, see 8-2-8; for base coming loose, see 8-4-2h; and for oversliding, see 2-25-1.

SECTION 41 WILD PITCH

A wild pitch is one which cannot be handled by the catcher with ordinary effort (9-6-1).

SECTION 42 PLAYING FIELD

The playing field includes both fair and foul territory. Any other areas beyond the playing field are defined as being outside the playing field (dead ball area). Any wall, fence, barricade, rope, wire, marked or imaginary line is considered a part of the playing field. Any areas beyond those boundaries are outside the playing field.

Rule 3***Substituting—Coaching—
Bench and Field Conduct—
Charged Conferences*****SECTION 1 SUBSTITUTING**

ART. 1 . . . After the umpire has received the official lineup cards prior to the game, the player listed as pitcher shall pitch until the first opposing batter has been put out or has advanced to first base. In any other case, a substitute may replace a player of his team when the ball is dead and time has been called. The umpire-in-chief shall record any reported substitutions on the lineup card and then announce immediately any change(s) to the opposing team. Projected substitutions are not allowed. In each of the following situations, the ball is declared live by the umpire-in-chief. Should there be no announcement of substitutions, a substitute has entered the game when the ball is live and:

- a. a runner takes the place of a runner he has replaced,
- b. a pitcher takes his place on the pitcher's plate,
- c. a fielder reaches the position usually occupied by the fielder he has replaced, or
- d. a batter takes his place in the batter's box.

PENALTY: If the starting pitcher does not face one batter, he may play another position, but not return to pitch.

For discovery of an illegal player (2-36-3) on offense by an umpire or either team, that player shall be called out and restricted to the bench/dugout for the duration of the game. An illegal player discovered on defense shall be restricted to the bench/dugout for the duration of the game. If a restricted player re-enters the game on offense, he shall be called out immediately and ejected upon discovery by an umpire or either team. If he is a defensive player, he shall be ejected upon discovery by an umpire or either team.

The penalty for illegal substitution shall supersede the penalty for batting out of order.

If the player should score a run, advance or cause a play to be made that allows another runner(s) to advance, discovery must be made by an umpire or either team before the first pitch to the next batter of either team. This would invalidate the action of the illegal offensive player. Any out(s) made on the play stands and all other runners return to the base(s) occupied at the time of the pitch.

In a game-ending situation, discovery must be made before all infielders leave the diamond (i.e., all infielders cross the foul lines).

An illegal player on defense shall be replaced immediately upon discovery by the umpire or either team. If an illegal player on defense is involved in a play, and the infraction is discovered by an umpire or either team prior to the first pitch to the next batter of either team, the team on offense has the option to let the play stand or to allow the batter to bat again.

Any player for whom an illegal player substitutes may re-enter only if he is eligible to do so under the re-entry rule (3-1-3).

ART. 2 . . . If a pitcher is replaced while his team is on defense, the substitute pitcher shall pitch to the batter then at bat, or any substitute for that batter, until such batter is put out or reaches first base, or until a third out has been made. To ensure that the requirements of this article be fulfilled, the umpire will deny any coach-defensive player conference that will violate the rule. If a pitcher is incapacitated or guilty of flagrant unsportsmanlike conduct, this rule is ignored. A player may be removed as pitcher and returned as pitcher only once per inning, provided the return as pitcher does not violate either the pitching, substitution or charged conference rule. If the pitcher, because of an injury or being incapacitated, is replaced as pitcher and the above rule is not satisfied, or if his replacement requires more warm-up throws than permitted in 6-2-2 exception, he cannot return to the game as a pitcher.

ART. 3 . . . Any of the starting players may be withdrawn and re-entered once, including a player who was the designated hitter, provided such player occupies the same batting position whenever he is in the lineup. The pitcher is governed by the provisions of Article 2 above. A substitute who is withdrawn may not re-enter. A starting pitcher who is replaced in the top of the first inning while his team is at bat shall be governed by the provisions of Articles 1 and 2 above.

ART. 4 . . . A hitter may be (not mandatory) designated for any one starting player (not just pitchers) and all subsequent substitutes for that player in the game. A starting defensive player cannot be listed as the designated hitter in the starting lineup. A designated hitter for said player shall be selected prior to the start of the game, and his name shall be included on the lineup cards presented to the umpire-in-chief and to the official scorer. Failure to declare a designated hitter prior to the game precludes the use of a designated hitter in that game. If a pinch hitter or pinch runner for the designated hitter is used, that player becomes

the new designated hitter. The player who was the designated hitter may re-enter as the designated hitter under the re-entry rule. A designated hitter and the player for whom he is batting are locked into the batting order. No multiple substitutions may be made that will alter the batting rotation. The role of the designated hitter is terminated for the remainder of the game when:

- a. the defensive player, or any previous defensive player for whom the designated hitter batted, subsequently bats, pinch-hits or pinch-runs for the designated hitter; or
- b. the designated hitter or any previous designated hitter assumes a defensive position.

ART. 5 . . . Any player who exhibits signs, symptoms or behaviors consistent with a concussion (such as loss of consciousness, headache, dizziness, confusion or balance problems) shall be immediately removed from the game and shall not return to play until cleared by an appropriate health-care professional. (See NFHS Suggested Guidelines for Management of Concussions on page 73.)

ART. 6 . . . A player or coach who is bleeding or who has an open wound shall be prohibited from participating further in the game until appropriate treatment has been administered. If medical care or treatment can be administered in a reasonable amount of time, the individual would not have to leave the game. The length of time that is considered reasonable is umpire judgment. The re-entry rule applies to starters. If there is any amount of blood on the uniform, it shall be changed or cleaned before that individual participates again. (See Communicable Disease Procedures on page 75.)

SECTION 2 COACHING

ART. 1 . . . One player or coach may occupy each coach's box while his team is at bat. A coach who is not in the uniform of the team shall be restricted to the bench/dugout. However, a coach may leave the bench/dugout to attend to a player who becomes ill or injured. He may address base runners or the batter. Coaches may wear prostheses and use mobility devices. Any member of the team at bat, who has not been ejected for unsportsmanlike conduct, may occupy a coach's box.

ART. 2 . . . No coach shall physically assist a runner during playing action.

PENALTY: The ball is dead at the end of playing action. The involved batter-runner or runner is out and any additional outs made on the play stand. Runners not put out return to bases occupied at the time of the infraction.

ART. 3 . . . No offensive team personnel, other than the base coach, shall be near a base for which a runner is trying so that a fielder may be confused; nor be on or near the baseline in such a way as to draw a throw; nor shall the base coach or members of the team at bat fail to vacate any area needed by a fielder in his attempt to put out a batter or runner.

If a thrown live ball unintentionally touches a base coach in foul territory, or a

pitched or thrown ball touches an umpire, the ball is live and in play. If the coach is judged by the umpire to have interfered intentionally with the thrown ball, or interferes in fair territory, the interference penalty is invoked.

PENALTY: The ball is dead immediately and the runner is out. The batter-runner or runner may be out as in 7-4-1f and 8-4-2g. Other runners return as in 8-2-8.

ART. 4 . . . The head coach must attend the pregame conference, if available.

PENALTY: The head coach will be restricted to the dugout for the remainder of the game, except to attend to a sick or injured player, if he refuses to attend the pregame conference.

SECTION 3 BENCH AND FIELD CONDUCT

ART. 1 . . . A coach, player, substitute, attendant or other bench personnel shall not:

- a. leave the dugout during a live ball for an unauthorized purpose;
- b. fake a tag without the ball;
- c. carelessly throw a bat;
- d. wear jewelry (players participating in the game) or wear bandannas;
- e. hit the ball to players on defense after the game has started;
- f. use television monitoring or replay equipment for coaching purposes during the course of the game;

PENALTY: At the end of playing action, the umpire shall issue a warning to the coach of the team involved and the next offender on that team shall be ejected, except for (f), where the coach shall be ejected. In (b), it is also obstruction (8-3-2).

- g. commit any unsportsmanlike act to include, but not limited to,
 1. use of words or actions to incite or attempt to incite spectators demonstrations,
 2. use of profanity, intimidation tactics, remarks reflecting unfavorably upon any other person, or taunting or baiting. The NFHS disapproves of any form of taunting that is intended or designed to embarrass, ridicule or demean others under circumstances including race, religion, gender or national origin.
 3. use of any language intended to intimidate,
 4. behavior in any manner not in accordance with the spirit of fair play;
 5. being in live ball territory (excluding team's bullpen area) during the opponent's infield practice prior to the start of the game.
 6. any member of the coaching staff who was not the head coach (or designee) in 3-2-4 leaving the vicinity of the dugout or coaching box to dispute a judgment call by an umpire.
 7. Confronting or directing unsportsmanlike conduct to the umpires after the game has concluded and until the umpires have departed the game site.
- h. enter the area behind the catcher while the opposing pitcher and catcher are in their positions;

- i. have any object in his possession in the coach's box other than a stopwatch, rule book, scorebook, a Personal Digital Assistant (PDA) or comparable electronic score-recording device which shall be used for scorekeeping purposes only;
- j. be outside the designated dugout (bench) or bullpen area if not a batter, runner, on-deck batter, in the coach's box or one of the nine players on defense;
- k. charge an umpire;
- l. use amplifiers or bullhorns for coaching purposes during the course of the game;

PENALTY: The umpire shall eject the offender from the game, unless the offense is judged to be of a minor nature. The umpire may warn the offender and then eject him if he repeats the offense. The warning or ejection shall be made at the end of playing action. Failure to comply shall result in the game being forfeited. For coaches who violate g (1-5), h, i, j, k, or l, the umpire may (1) restrict the offender to bench/dugout for the remainder of the game or (2) eject the offender. For violation of g (6), both the head coach and the offending coach shall be restricted to the dugout for the remainder of the game, or if the offense is judged severe enough, the umpire may eject the offender and restrict or eject the head coach. Any coach restricted to the bench shall be ejected for further misconduct. A coach may leave the bench/dugout to attend to a player who becomes ill or injured. In g(7), the state association shall determine appropriate action.

- m. deliberately throw a bat, helmet, etc.;
- n. initiate malicious contact on offense or defense;
- o. call "Time" or use any command or commit any act for the purpose of causing a balk; or
- p. use tobacco or tobacco-like products within the confines of the field.
- q. leave their positions or bench area during a fight or physical confrontation.

PENALTY: The umpire shall eject the offender from the game. Failure to comply shall result in game being forfeited. In (n), the ball is immediately dead, if on offense, the player is ejected and declared out, unless he has already scored. If the defense commits the malicious contact, the player is ejected; the umpire shall rule either safe or out on the play and award the runner(s) the appropriate base(s) he felt they would have obtained if the malicious contact had not occurred. In (q), a coach who attempts to prevent a fight or restore order is not in violation of the rule.

ART. 2 . . . A coach who is ejected shall leave the vicinity of the playing area immediately and is prohibited from further contact, direct or indirect, with the team during the remainder of the game. He may return when requested to attend to an ill or injured player.

ART. 3 . . . Players loosening up to bat shall remain in the area of their team's on-deck circle while the pitcher is warming up (1-2-3).

PENALTY: The umpire shall issue a team warning to the coach of the team involved. The next offender on that team shall be ejected.

ART. 4 . . . Whenever team members are loosening up in an area which is not protected by a fence or other structure, another member of the team with a glove must be positioned between them and the batter to protect them from a batted or thrown ball within the confines of the playing field. No one is to interfere with a live ball.

SECTION 4 CHARGED CONFERENCES

ART. 1 . . . Each team, when on defense, may be granted not more than three charged conferences during a seven-inning game, without penalty, to permit coaches or their non-playing representatives to confer with a defensive player or players. In an extra inning game, each team shall be permitted one charged conference each inning while on defense without penalty. The number of charged conferences permitted is not cumulative. A request for time for this purpose shall be made by a coach, player, substitute or an attendant. Time granted for an obviously incapacitated player shall not constitute a charged conference. Prior to accumulating three charged conferences in seven innings or less, a conference is not charged if the pitcher is removed as pitcher.

PENALTY: After three charged conferences in a seven-inning game, or for any charged conference in excess of one in each extra inning, the pitcher shall be removed as pitcher for duration of the game.

ART. 2 . . . Each team, when on offense, may be granted not more than one charged conference per inning to permit the coach or any of that team's personnel to confer with base runners, the batter, the on-deck batter or other offensive team personnel. The umpire shall deny any subsequent offensive team requests for charged conferences.

ART. 3 . . . A defensive charged conference is concluded when the coach or non-playing representative crosses the foul line if the conference was in fair territory. If the conference was in foul territory, the conference concludes when the coach or non-playing representative initially starts to return to the dugout/bench area.

ART. 4 . . . An offensive charged conference is concluded when the coach or team representative initially starts to return to the coach's box or dugout/bench area. For Articles 3 & 4, if a coach who has been restricted to the dugout/bench area is involved in a charged conference, that conference shall end when the players involved initially start to return to their positions on the field. The coach shall be given a reasonable amount of time for the charged conference as determined by the umpire-in-chief.

ART. 5 . . . When either team has a charged conference, the other team may also have a conference, which is not charged, provided the conference concludes when the opposing team's charged conference concludes, so that the game is not further delayed.

Rule **4** *Starting and Ending Game*

SECTION 1 STARTING A GAME

ART. 1 . . . The home coach shall decide whether the grounds and other conditions are suitable for starting the game. After the game starts, the umpires are sole judges as to whether conditions are fit for play and as to whether or not conditions are suitable for starting the second game of a scheduled double-header (two games between the same teams during the same day).

ART. 2 . . . If there are unusual conditions, such as spectators or obstacles too near the playing field, the home coach shall propose special ground rules. If sanctioned by the visiting team, these shall be in force. If the teams cannot agree, the umpires shall formulate ground rules. Ground rules do not supersede a rules book rule. All special rules shall be announced.

- a. The field should be clearly marked. Markings should include poles along the foul lines at least 210 feet past first and third and vertical foul line markings on any wall that limits the outfield.
- b. When a fair or foul fly comes down near a stand or fence, 7-4-1d applies. If there is a screen behind the catcher or other permanent obstruction in front of the stand, a batted ball that goes behind these becomes dead and cannot be caught. It is recommended that no such obstruction be less than 60 feet from the diamond.
- c. Wild pitches, overthrows and batted balls that go over, through or wedges in a fence are governed by Rule 8-3-3. If the field has unusual obstructions, ground rules should, as nearly as possible, be similar to this rule.
- d. For a special field condition, such as a drain pipe that makes a spot where it is impossible or very difficult for a fielder to retrieve the ball, the ball should become dead if it goes to that spot and each runner's advance should be limited to two bases.
- e. In an unfenced field where cars are parked along the foul lines, umpires should consider these the same as bleachers and ball becomes dead if it bounces into the line of cars. They should anticipate such a situation and announce the ground rule in advance.

ART. 3 . . . Before game time, the home team and then the visiting team shall deliver their respective batting orders in duplicate to the umpire-in-chief. The umpire then shall permit inspection by both head coaches and/or captains if available. Each team's lineup card shall list a minimum of nine players to start the game (see 4-4-1f for game to continue with less than nine players). The substitution regulations, as in Rule 3, are then in effect.

- a. The umpire-in-chief shall emphasize to both head coaches and captains that all participants are expected to exhibit good sporting behavior throughout the game(s).

- b. Prior to the start of the game, the umpire-in-chief shall receive verification from each head coach that his participants are properly equipped in accordance with NFHS rules. In addition, each coach shall verify that his participants are using only legal equipment, including bats that are unaltered from the manufacturer's original design and production and that meet the provisions of 1-3-2, and helmets that meet the provisions of 1-5-1 and are free of cracks and damage.

PENALTY: On the first violation of 4-1-3b for entering the box with an illegal bat, the penalty for an illegal bat is applied (7-4-1a) and the head coach shall be restricted to the bench/dugout for the remainder of the game. On the second violation for entering the box with an illegal bat, the penalty for an illegal bat is applied and the head coach shall be ejected. On subsequent violations for entering the box with an illegal bat, the penalty for an illegal bat is applied and the designated head coach shall be ejected. On detected violations of 4-1-3b for the use of a damaged helmet, the helmet shall be immediately removed from play.

ART. 4 . . . The visiting team shall be the first to take its turn at bat. On a neutral field or by agreement, either team may be designated as Home Team.

ART. 5 . . . The game begins when the umpire calls "Play" after all infielders, pitcher, catcher and batter are in position to start the game.

SECTION 2 ENDING A REGULATION GAME

ART. 1 . . . A regulation interscholastic game consists of seven innings (turns at bat) unless extra inning(s) are necessary because of a tie score, or unless shortened because the home team needs none of its half of the seventh or only a fraction of it (Art. 2); or because of weather, or darkness (Art. 3). Each team must have nine players in its lineup throughout the game (see 4-4-1f Note 2). Otherwise, the game will be forfeited. A forfeited game is regulation, regardless of innings played (4-4-2).

ART. 2 . . . The game ends when the team behind in score has completed its turn at bat in the seventh inning, or any inning thereafter if extra innings are necessary. If the home team scores a go-ahead run in the bottom of the seventh inning, or in any extra inning, the game is terminated at that point. Any game that is tied at the end of 4½ or at least five full innings when the game is called shall be a tie game, unless the state association has adopted a specific game ending procedure. Batting and fielding records are counted, but the game is not counted in computing percentages of games won and lost. By state association adoption, the game shall end when the visiting team is behind 10 or more runs after 4½ innings, or after the fifth inning, if either team is 10 runs behind and both teams have had an equal number of times at bat.

- a. If an over-the-fence home run is hit, all runs score before the game is terminated.
- b. Two seven-inning games shall constitute a doubleheader.

ART. 3 . . . If weather or darkness interferes with play so that the game is called (ended) by the umpire, it is a regulation game:

- a. if five full innings have been played, or if the home team has scored an equal or greater number of runs in four or four and a fraction turns at bat than the visiting team has scored in five turns at bat; or
- b. if play has gone beyond five full innings.

If the game is called when the teams have not had an equal number of completed turns at bat, the score shall be the same as it was at the end of the last completed inning; except that if the home team in its half of the incomplete inning, scores a run (or runs) which equals or exceeds the opponent's score, the final score shall be as recorded when the game is called.

ART. 4 . . . A state association may adopt game-ending procedures that determine how games are ended, including suspended games. However, if a state does not adopt game ending procedures, by mutual agreement of the opposing coaches and the umpire-in-chief, any remaining play may be shortened or the game terminated. If a state association has adopted game-ending procedures, only those game-ending procedures may be used, should the opposing coaches wish to terminate a game.

SECTION 3 CALLED GAME

If a game is called before completion of the number of innings and conditions as specified in 4-2-3, the umpire shall declare the contest "no game," unless play is terminated by 4-2-4. By state association adoption, a regulation called game where a winner cannot be determined (see 4-2-3) shall be counted as $\frac{1}{2}$ game won and $\frac{1}{2}$ game lost for each team.

SECTION 4 FORFEITED GAME

ART. 1 . . . A game shall be forfeited to the offended team by the umpire when a team:

- a. is late in appearing or in beginning play after the umpire calls "Play." State associations are authorized to specify the time frame and/or circumstance before a forfeit will be declared for a late arrival by one of the teams; or
- b. refuses to continue play after the game has started; or
- c. delays more than a reasonable amount of time in resuming play, or in obeying the umpire's order to remove a player for violation of the rules; or
- d. persists in tactics designed to delay or shorten the game; or
- e. willfully and persistently violates any of the rules after being warned by the umpire; or
- f. is unable to provide at least nine players to start the game or cannot provide eight players to finish the game; or

NOTES:

1. An out will be called each time that spot in the batting order comes to bat. If the offensive player must be substituted for after reaching base, the most recent batter not on base is allowed to run for that player.

2. A team playing with fewer than nine players may return to nine players.
 g. on its home field, fails to comply with the umpire's order to put the field in condition for play.

ART. 2 . . . Score of a forfeited game is 7 to 0 except if the game is forfeited after the number of innings required for a regulation game and the offending team is behind. Then the score remains as recorded. If the offending team is leading, the score shall be 7 to 0.

SECTION 5 PROTESTED GAME

It is optional on the part of a state association as to whether protests are permitted. When allowed, protests are permitted regarding rules one through nine only. When protests are submitted to organizations which do allow the filing, such protest must be submitted using a prescribed procedure (10-2-3i). All individual and team averages shall be included in the official records, except that no pitcher shall be credited with a victory or charged with a loss in such a game, if the game is not regulation.

Rule 5 *Dead Ball — Suspension of Play*

SECTION 1 DEAD BALL

ART. 1 . . . Ball becomes dead immediately when:

- a. a pitch touches a batter or his clothing (8-1-1d), a runner (8-3-1a);
 1. The ball becomes dead even though the batter strikes at it (8-1-1d).
- b. the ball is illegally batted (7-3-2 and 7-4-1a) or is intentionally struck a second time with the bat as in 8-4-1d;
- c. the batter enters the batter's box with an illegal bat;
- d. a foul ball (2-16-1):
 1. touches any object other than the ground or any person other than a fielder; or
 2. goes directly from the bat to the catcher's protector, mask or person without first touching the catcher's glove or hand;
 3. or becomes an uncaught foul; or
- e. there is interference by a runner, batter-runner (8-4-1g), or a retired runner (3-3-1n, 8-4-1a, h or 8-4-2b, e, f, g or k), the batter (7-3-5), or by any person (3-2-3);
- f. a fair batted ball:
 1. touches a runner or an umpire before touching any fielder and before passing any fielder other than the pitcher,
 2. touches a runner after passing through or by an infielder and another infielder could have made a play on the ball,
 3. touches a spectator,
 4. goes over or through or wedges in the field fence, or

DEAD BALL AND DELAYED DEAD BALL TABLE
Ball Dead Immediately

Activity	Reference	Awards or Penalties	References
1. Illegal pitch (no runner).....	5-1-1k	The pitch is ruled a ball.....	6-1-2, 3; Pen: 8-3-1a
2. Pitch touches batter.....	5-1-1a	Batter awarded first base except when he permits the ball to touch him or pitch is a strike.....	8-1-1d
3. Pitch touches runner.....	5-1-1a	All runners advance one base except when pitch is a strike for third out.....	8-3-1a, 6-1-4
4. Illegally batted ball.....	5-1-1b	Batter is out. Runners return.....	7-3-2; 7-4-1a, 8-2-2
5. Intentionally hitting ball second time.....	5-1-1b	Runners return to bases occupied at time of pitch.....	8-4-1d; 8-2-2
6. An uncaptured foul.....	5-1-1d	Batter is out. Also batter-runner if interference prevented a double play and a runner is ejected on the later. Other runners return. For malicious contact the player guilty of the infraction is ejected.....	3-3-1c; 8-2-6; 8-4-1a, b; 8-4-2g, k; 8-4-2b, f
7. Interference by runner or retired runner (including malicious contact).....	5-1-1e	Runner is out and another runner is out if interference prevented a possible double play.....	8-4-2g
8. Interference with fielder by runner attempting to catch foul fly ball.....	5-1-1e	Runner is out. Other runners return.....	8-2-6; 7-3-5
9. Interference by others connected with team.....	5-1-1e	Award all runners home base.....	8-3-3a
10. Fair ball over fence in flight or prevented by spectator or player's detached equipment.....	5-1-1f	Award or penalize according to umpire's judgment.....	8-3-3a
11. Fair ball touches a spectator.....	5-1-1f	Award all runners two bases from base occupied at time of pitch.....	8-3-3c
12. Fair ball bounces over, through or lodges in fence or lodges in player's uniform or equipment.....	5-1-1f	Hit runner is out. Batter awarded first base and credited with single. Others return to base occupied at time of interference unless forced by batter-runner.....	8-4-2k
13. Fair ball touches runner before it touches an infielder or after it passes any infielder except the pitcher and another fielder has a play.....	5-1-1f	Runners return to bases occupied at time or pitch unless forced by batter-runner. Batter awarded first base and credited with a single.....	8-1-2b
14. Fair batted ball touches umpire before it touches a fielder or passes any fielder except the pitcher.....	5-1-1f	Award all runners two bases.....	8-3-3c; 8-3-4
15. A thrown ball, not by pitcher from plate, goes into bench, stand, through or over fence.....	5-1-1g	Award all runners one base.....	8-3-3d
16. A pitch or other thrown ball from plate goes into stand, bench, over or through fence, backstop, reaches a spectator (in live ball area) or lodges in umpire's or catcher's equipment.....	5-1-1g	Runners return to bases they had reached or passed when ball becomes dead.....	8-2-6
17. Umpire handles a live ball or calls time to inspect ball or for other reason, including items in 5-1 or umpire inadvertently declares "Foul" as in 2-16-1e.....	5-1-1h	Award all runners one base except when caught ball is third out....	8-3-3d
18. Fair or foul ball is caught by a fielder, who then steps or falls with both feet from field of play over any boundary or barrier such as a fence, rope, chalk line or pre-game determined imaginary line or into a stand, bench or dugout.....	5-1-1i	Batter is out and all runners return to base occupied at time of pitch.....	8-4-1c
19. Infielder intentionally drops a fair fly, fair line drive or fair bunt in flight with at least first base occupied and with less than two outs.....	5-1-1j		

20. Balk.....	5-1-1k	20. All runners advance one base. Batter remains at bat.....	6-2-4, 5, 8-3-1a; 8-3-4
21. Umpire gives "do not pitch signal".....	5-1-1h	21. No play can take place.....	5-2-1
22. Award intentional base on balls.....	5-1-3	22. Batter awarded first base.....	8-1-1c
23. Batter enters box with an illegal bat.....	5-1-3	23. Batter is out.....	7-4-1a; 1-3-5
24. Batter refuses to enter box after being warned by umpire.....	7-3-4	24. Strike is called.....	7-3-1 Penalty
25. Interference by batter who hits throw from the pitcher, not in contact with pitcher's plate when runner is advancing to home base.....	5-1-1b	25. With less than two outs, the runner is out. Otherwise batter is out.....	7-3-5 Penalty
26. A batted, thrown or pitched ball touches a designated media area or anyone or anything that is entirely or partially in the designated media area.....	5-1-11	26. Award each runner the following two bases — fair batted ball or thrown ball not by pitcher in contact with the pitcher's plate; one base — throw or pitch by pitcher.....	8-3-3c
27. Defensive Malicious Contact.....	5-1-1m	27. Umpire will rule safe or out on the play and award runner(s) appropriate base(s) per his judgement.....	8-4-2e

After Infraction, Ball Not Dead Until Umpire Calls "Time"

Activity	Reference	Awards or Penalties	References
1. Interference by batter when attempted put out is on runner other than at home.....	5-1-2a	1. With two out, batter is out. Otherwise, if attempt on runners unsuccessful, ball is dead, batter is out and runners return. If third strike, batter is out and umpire can call a second out.....	7-3-5; 8-2-6; 8-4-2g
2. Interference by batter when runner is advancing to home plate (other than hitting a throw from the pitcher, not in contact with pitcher's plate).....	5-1-2a	2. Runner is out unless two are out, then batter is out. If runner is put out, ball remains alive.....	7-3-5; 8-4-2i
3. Obstruction with batter by catcher or fielder.....	5-1-2b	3. If batter and all runners attempting to steal or who are forced do not advance, award each one base.....	8-1-1a; 8-3-1c
4. Obstruction.....	5-1-2b; 5-1-3	4. If obstructed runner and all other runners hindered by the obstruction do not reach bases they otherwise would have reached, award runner or runners such bases.....	8-3-2
5. Intentionally touching batted ball with detached player equipment over fair ground, or over foul ground which might become fair ball.....	5-1-2b	5. Award batter-runner and runners three bases if not made.....	8-3-3b
6. Intentionally touching thrown ball (including a pitch) with detached player equipment.....	5-1-2b	6. Award runners two bases if not made.....	8-3-3c
7. Offensive team personnel calls "Time" or uses any other command or commits an act for the purpose of trying to cause opposing pitcher to balk.....	5-1-2d	7. No runners allowed to advance. Eject offender from the game.....	3-3-10
8. Interference with catcher by umpire.....	5-1-2e	8. If runner is not put out, runners return.....	8-3-5
9. Deliberately removing batting helmet in live ball territory while ball is alive.....	5-1-2e	9. Team warning. Subsequent players on that team to violate rule are ejected.....	1-1-5
10. A coach physically assists a runner.....	5-1-2f	10. Involved batter-runner or runner is out. Outs on play stand. Other runners return to bases occupied at time of infraction.....	3-2-2
11. Use of illegal glove/mitt.....	5-1-2g	11. Award four bases for home run over fence, three bases for other fair batted ball, two bases for thrown or pitched ball.....	8-3-3a, b, c

- 5. lodges in players equipment or uniform; or
- g. a pitch or any other thrown ball:
 - 1. is touched by a spectator;
 - 2. is intentionally touched by a non-participating squad member;
 - 3. goes into a stand or other dead-ball area or players' bench (even if it rebounds to the field), or over or through or wedges in the field fence (8-3-3c or d);
 - 4. lodges in an umpire's, catcher's or offensive player's equipment or uniform; or
- h. the umpire handles a live ball or calls "Time" for inspecting the ball or for any other reason, including items in Section 2 or gives the "Do Not Pitch Signal" or inadvertently announces "Foul" on a ball that touches the ground; or
- i. a fielder, after catching a fair or foul ball (fly or line drive), leaves the field of play by stepping with both feet or by falling into a bench, dugout, stand, bleacher, or over any boundary or barrier such as a fence, rope, chalk line, or a pregame determined imaginary boundary line; or
- j. an infielder intentionally drops a fair fly, fair line drive or fair bunt in flight with at least first base occupied and with less than two outs.

EXCEPTION: Infield-fly rule (2-19).
- k. a balk or an illegal pitch is committed; or
- l. a batted, thrown or pitched ball touches a designated media area or anyone or anything that is entirely or partially in the designated media area.
 - 1. The umpire has the authority to remove any member of the media for not staying in or keeping their equipment in the designated dead ball area.
- m. when malicious contact (offensive or defensive) occurs;

ART. 2 . . . It is a delayed dead ball when:

- a. there is interference by a batter (Exception 7-3-5 Penalty),
 - 1. When the batter interferes with the catcher attempting to play on a runner, if an out does not result at the end of the catcher's throw, the ball shall become dead immediately.
- b. a catcher or any fielder obstructs a batter or runner; or obstructs the ball through use of detached player equipment (8-3-3);
- c. umpire interferes with the catcher who is attempting to throw;
- d. any personnel connected with the offensive team calls "Time" or uses any other command or commits any act for the purpose of trying to cause the opposing pitcher to balk;
- e. anyone who is required to wear a batting helmet deliberately removes his helmet, while the ball is in live-ball territory and the ball is live;
- f. a coach physically assists a runner (see 3-2-2); or
- g. a ball touches an illegal glove/mitt.

ART. 3 . . . The ball becomes dead when time is taken to make an award when a catcher or any fielder obstructs a runner, when an intentional base on balls is to be awarded, or when baserunning penalties are imposed.

ART. 4 . . . After a dead ball, the ball becomes live when it is held by the pitcher in a legal pitching position, provided the pitcher has engaged the pitcher's plate, the batter and the catcher are in their respective boxes, and the umpire calls "Play" and gives the appropriate signal.

SECTION 2 SUSPENSION OF PLAY

ART. 1 . . . "Time" shall be called by the umpire and play is suspended when:

- a. the ball becomes dead (5-1-2, 5-1-3);
- b. the umpire considers the weather or ground conditions unfit for play;
 1. After 30 minutes, he may declare the game ended.
- c. a player, bench personnel or spectator is ordered from the grounds, or a player is ordered to secure protective equipment;
- d. an umpire or player is incapacitated, except that if injury occurs during a live ball, time shall not be called until no further advance or putout is possible;
 1. If there is a medical emergency or if, in the umpire's judgment, further play could jeopardize the injured player's safety, "Time" shall be called.
- e. a player or coach requests "Time" and it is granted by the umpire for a substitution, conference with the pitcher or for similar cause; or
- f. the umpire suspends play for any other cause, including an award of a base after an infraction, or for inspection of the ball.

ART. 2 . . . When the ball becomes dead:

- a. no action by the defense can cause a player to be put out (unless it is a dead-ball appeal);
- b. a runner may return to a base he left too soon on a caught fly ball or that was not touched during a live ball;
 1. A runner who is on or beyond a succeeding base when the ball became dead, or advances and touches a succeeding base after the ball became dead, may not return and shall be called out upon proper and successful appeal (8-4-2q).
- c. any runner may advance when awarded a base(s) for an act which occurred before the ball became dead provided any base in (b) above is retouched and all bases are touched in their proper order (8-1-2, 8-2-1, 8-3)

Rule 6

Pitching

SECTION 1 PITCHING

ART. 1 . . . The pitcher shall pitch while facing the batter from either a windup position (Art. 2) or a set position (Art 3). The position of his feet determine whether he will pitch from the windup or the set position. He shall take his sign from the catcher with his pivot foot in contact with the pitcher's plate. The pitching regulations begin when he intentionally contacts the pitcher's plate. Turning the shoulders to check runners while in contact with the pitcher's plate in the set position is legal. Turning the shoulders after bringing the hands together during

or after the stretch is a balk. He shall not make a quick-return pitch in an attempt to catch a batter off balance. The catcher shall have both feet in the catcher's box at the time of the pitch. If a pitcher is ambidextrous, the umpire shall require the pitcher to face a batter as either a left-handed pitcher or right-handed pitcher, but not both.

ART. 2 . . . For the wind-up position, the pitcher is not restricted as to how he shall hold the ball. A pitcher assumes the windup position when his hands are: (a) together in front of the body; (b) both hands are at his side; (c) either hand is in front of the body and the other hand is at his side. The pitcher's non-pivot foot shall be in any position on or behind a line extending through the front edge of the pitcher's plate. He is limited to not more than two pumps or rotations. After he starts his movement to pitch, he must continue the motion without interruption or alteration. With his feet in the wind-up position, the pitcher may only deliver a pitch or step backward off the pitcher's plate with his pivot foot first. After the pitcher has placed his pivot foot clearly behind the plate, he has the right to change to the set position or throw or feint to a base the same as that of any infielder. During delivery, he may lift his non-pivot foot in a step forward, a step sideways, or in a step backward and a step forward, but he shall not otherwise lift either foot.

ART. 3 . . . For the set position, the pitcher shall have the ball in either his gloved hand or his pitching hand. His pitching hand shall be down at his side or behind his back. Before starting his delivery, he shall stand with his entire non-pivot foot in front of a line extending through the front edge of the pitcher's plate and with his entire pivot foot in contact with or directly in front of the pitcher's plate. He shall go to the set position without interruption and in one continuous motion. He shall come to a complete and discernible stop (a change of direction is not considered an acceptable stop) with the ball in both hands in front of the body and his glove at or below his chin. Natural preliminary motions such as only one stretch may be made. During these preliminary motions and during the set position until a delivery motion occurs, the pitcher may turn on his pivot foot or lift it in a jump turn to step with the non-pivot foot toward a base while throwing or feinting as outlined in 6-2-4 and 2-28-5, or he may lift his pivot foot in a step backward off the pitcher's plate which must be in or partially within the 24-inch length of the pitcher's plate. In order to change to the wind-up position, he must first step clearly backward off the pitcher's plate with his pivot foot first. After the pitcher has placed his pivot foot on the ground clearly behind the plate, he then has the right to throw or feint to a base the same as that of any other infielder.

PENALTY (ART. 1, 2, 3): The ball is dead immediately when an illegal pitch occurs. If there is no runner, a ball is awarded the batter. If there is a runner, such illegal act is a balk. In both situations, the umpire signals dead ball.

ART. 4 . . . Each legal pitch shall be declared by the umpire as a strike, ball,

fair or foul hit or a dead ball. A pitch dropped during delivery and which crosses a foul line shall be called a ball. Otherwise, it will be called no pitch. A pitch dropped during delivery with at least one runner on base would be a balk if it does not cross a foul line.

ART. 5 . . . When a pitcher is attempting to field a batted or thrown ball or is throwing to a base while his pivot foot is clearly off his plate, his status is that of an infielder except that if a batted ball passes but does not touch him and then strikes an umpire or a runner, the ball may become dead because of interference (8-4-2g, 8-4-2k).

ART. 6 . . . Each state association shall have a pitching restriction policy to afford pitchers a reasonable rest period between pitching appearances.

SECTION 2 INFRACTIONS BY PITCHER

ART. 1 . . . Illegal acts include:

- a. applying a foreign substance to the ball;
- b. spitting on the ball or glove;
- c. rubbing the ball on the glove, clothing or person if the act defaces the ball;
- d. discoloring the ball with dirt;
- e. bringing the pitching hand in contact with the mouth without distinctly wiping off the pitching hand before it touches the ball;
- f. wearing any items on the hands, wrists or arms that may be distracting to the batter;
- g. wearing or placing tape, bandages or other foreign material (other than rosin) on the fingers or palm of his pitching hand that could come in contact with the ball;
- h. wearing a glove/mitt that includes the colors white or gray;
- i. wearing exposed undershirt sleeves that are white or gray.

NOTE: Under umpire supervision, the pitcher may dry his hands by using a finely meshed cloth bag of powdered rosin. He may rub the ball with his bare hands to remove any extraneous coating.

PENALTY: For defacing the ball (a-d), the ball is dead immediately. The umpire may eject the pitcher. If such defaced ball is pitched and then detected, it is an illegal pitch. For infraction (e), a ball shall be awarded each time a pitcher violates this rule and subsequently engages the pitching plate. For infraction (f-i), the infraction must be corrected before the next pitch. In (f), the umpire has sole authority to judge whether or not an item is distracting and shall have that item removed.

ART. 2 . . . Delay of the game includes:

- a. throwing to any player other than the catcher, when the batter is in the batter's box, unless it is an attempt to retire a runner;

PENALTY: The pitcher shall be ejected from the game after a warning.

- b. consuming time as the result of the coach or his representative conferring with a defensive player or players after being charged with three conferences (3-4-1);

PENALTY: The pitcher shall be replaced as pitcher for the duration of the game.

- c. failing to pitch or make or attempt a play, including a legal feint, within 20 seconds after he has received the ball.

PENALTY: The batter shall be awarded one ball.

NOTE: Umpires shall require that the ball be returned promptly to the pitcher.

EXCEPTION: The starting pitchers may warm up by using not more than eight throws, completed in one minute (timed from the first throw). When a pitcher is replaced during an inning or prior to an inning, the relief pitcher may not use more than eight throws completed in one minute (timed from the first throw). At the beginning of each subsequent inning, the pitcher may warm up by using not more than five throws, completed in one minute (timed from the third out of the previous half-inning) (3-1-2). In either case, the umpire-in-chief may authorize more throws because of an injury or inclement weather.

ART. 3 . . . Intentionally pitch close to a batter.

PENALTY: The pitcher shall be ejected if the act is judged to be intentional. In case of doubt, the umpire may first warn the pitcher.

ART. 4 . . . Balk. If there is a runner or runners, any of the following acts by a pitcher while he is touching the pitcher's plate is a balk:

- a. any feinting toward the batter or first base, or any dropping of the ball (even though accidental) and the ball does not cross a foul line (6-1-4);
- b. failing to step with the non-pivot foot directly toward a base (occupied or unoccupied) when throwing or feinting there in an attempt to put out, or drive back a runner; or throwing or feinting to any unoccupied base when it is not an attempt to put out or drive back a runner;
- c. making an illegal pitch from any position (6-1, 6-2-1a-d);
- d. failing to pitch to the batter in a continuous motion immediately after any movement of any part of the body such as he habitually uses in his delivery;
 - 1. If the pitcher, with a runner on base, stops or hesitates in his delivery because the batter steps out of the box (a) with one foot or (b) with both feet or (c) holds up his hand to request "Time," it shall not be a balk. In (a) and (c), there is no penalty on either the batter or the pitcher. The umpire shall call "Time" and begin play anew. In (b), a strike shall be called on the batter for violation of 7-3-1. In (a), (b) and (c), if the pitcher legally delivers the ball, it shall be called a strike and the ball remains live. Thus, two strikes are called on the batter in (b). If the umpire judges the batter's action to be a deliberate attempt to create a balk, he will penalize according to 3-3-1o.
- e. taking a hand off the ball while in a set position (6-1-3), unless he pitches to the batter or throws to a base or he steps toward and feints a throw to second or third base as in (b); or
- f. failing to pitch to the batter when the entire non-pivot foot passes behind the perpendicular plane of the back edge of the pitcher's plate, except when feinting or throwing to second base in an attempt to put out a runner.

ART. 5 . . . It is also a balk if a runner or runners are on base and the pitcher, while he is not touching the pitcher's plate, makes any movement naturally associated with his pitch, or he places his feet on or astride the pitcher's plate, or positions himself within approximately five feet of the pitcher's plate without having the ball.

Rule 7

Batting

SECTION 1 POSITION AND BATTING ORDER

ART. 1 . . . Each player of the team at bat shall become the batter and shall take his position within a batter's box, on either side of home plate, in the order in which his name appears on the lineup card as delivered to the umpire prior to the game (4-1-3). This order shall be followed during the entire game except that an entering substitute shall take the replaced player's place in the batting order. A batter is in proper order if he follows the player whose name precedes his in the lineup, even though such preceding batter may have batted out of order. An improper batter is considered to be at bat as soon as he is in the batter's box and the ball is live. When the improper batter's infraction is first discovered by either team, time may be requested and the improper batter replaced by the proper batter with the improper batter's ball and strike count still in effect, provided the infraction is detected before the improper batter is put out or becomes a base runner. Only the defensive team may appeal batting out of order after the batter has completed his time at bat. Any outs made on the play stand. An out for batting out of order supersedes an out by the improper batter on a play. While the improper batter is at bat, if a runner advances because of a stolen base, balk, wild pitch or passed ball, such advance is legal.

ART. 2 . . . After the first inning, the first batter in each inning shall be the player whose name follows that of the last batter who completed his time at bat in the preceding inning.

PENALTIES: For batting out of order (Art. 1 and 2):

- 1. A batter shall be called out, on appeal, when he fails to bat in his proper turn and another batter completes a time at bat in his place.**
- 2. When an improper batter becomes a runner or is put out and the defensive team appeals to the umpire before the first legal or illegal pitch, or, play or attempted play, or prior to an intentional base on balls or before the infielders leave the diamond if a half-inning is ending, the umpire shall declare the proper batter out and return all runners to the base occupied at the time of the pitch.**
- 3. When an improper batter becomes a runner or is put out and a legal pitch**

or illegal pitch has been delivered to the succeeding batter, or an intentional base on balls has occurred, or all infielders have left the diamond if a half inning is ending, and before an appeal is made, the improper batter becomes the proper batter and the results of his time at bat become legal.

4. When the proper batter is called out because he has failed to bat in turn, the next batter shall be the batter whose name follows that of the proper batter thus called out.
5. When an improper batter becomes a proper batter because no appeal is properly made as above, the next batter shall be the batter whose name follows that of such legalized improper batter. The instant an improper batter's actions are legalized, the batting order picks up with the name following that of the legalized improper batter.

NOTE: When several players bat out of order before discovery so that a player's time at bat occurs while he is a runner, such player remains on base, but he is NOT out as a batter.

SECTION 2 STRIKES, BALLS AND HITS

ART. 1 . . . A strike is charged to the batter when:

- a. a pitch enters any part of the strike zone in flight and is not struck at;
- b. a pitch is struck at and missed (even if the pitch touches the batter);
- c. a pitch becomes a foul when the batter has less than two strikes;
- d. a pitch becomes a foul tip (even on third strike) or a foul from an attempted bunt;
- e. a batter delays (6-2-4d-1 and 7-3-1); or
- f. a batted ball contacts the batter in the batter's box (foul ball).

ART. 2 . . . A ball is credited to the batter when a pitch is not touched by the bat and is not a strike or when there is an illegal pitch (6-1 Penalty, 6-1-4) or pitcher delay (6-2-2c).

ART. 3 . . . A foul ball or a fair hit (which may be a bunt) occurs when a pitch is touched by the bat of the batter who is in his box (2-5-1, 2-16-1,2).

SECTION 3 BATTING INFRACTIONS — A BATTER SHALL NOT:

ART. 1 . . . Delay the game by failing to take his position promptly in the batter's box within 20 seconds. The batter must keep at least one foot in the batter's box throughout the time at bat.

EXCEPTION: A batter may leave the batter's box when:

- a. the batter swings at a pitch,
- b. the batter is forced out of the box by the pitch,
- c. the batter attempts a "drag bunt,"
- d. the pitcher or catcher feints or attempts a play at any base,
- e. the pitcher leaves the dirt area of the pitching mound or takes a position more than five feet from the pitcher's plate after receiving the ball,
- f. a member of either team requests and is granted "Time,"

- g. the catcher leaves the catcher's box to adjust his equipment or give defensive signals, or
- h. the catcher does not catch the pitched ball.

PENALTY: For failure of the batter to be ready within 20 seconds after the ball has been returned to the pitcher, the umpire shall call a strike. If the batter leaves the batter's box, delays the game, and none of the above exceptions apply, the plate umpire shall charge a strike to the batter. The pitcher need not pitch, and the ball remains live.

ART. 2 . . . Hit the ball fair or foul while either foot or knee is touching the ground completely outside the lines of the batter's box or touching home plate.

ART. 3 . . . Disconcert the pitcher by stepping from the box on one side of home plate to the box on the other side while the pitcher is in position ready to pitch.

PENALTY: For infraction of Articles 2 and 3, the ball becomes dead immediately and the batter is out.

ART. 4 . . . Permit a pitched ball to touch him.

PENALTY: The batter remains at bat (pitch is a ball or strike) unless pitch was a third strike or ball four.

ART. 5 . . . Interfere with the catcher's fielding or throwing by:

- a. leaning over home plate,
- b. stepping out of the batter's box,
- c. making any other movement which hinders actions at home plate or the catcher's attempt to play on a runner, or
- d. failing to make a reasonable effort to vacate a congested area when there is a throw to home plate and there is time for the batter to move away.

PENALTY: When there are two outs, the batter is out. When there are not two outs and the runner is advancing to home plate, if the runner is tagged out, the ball remains live and interference is ignored. Otherwise, the ball is dead and the runner is called out. When an attempt to put out a runner at any other base is unsuccessful, the batter is out and all runners must return to bases occupied at the time of the pitch. If the pitch is a third strike and in the umpire's judgment interference prevents a possible double play (additional outs), two may be ruled out (8-4-2g).

ART. 6 . . . If the bat breaks and is hit by the ball or hits a runner or a fielder, no interference shall be called. If a whole bat is thrown and interferes with a defensive player attempting a play, interference will be called.

PENALTY: The batter is out and runners return. If, in the umpire's judgment, interference prevented a possible double play, two players may be ruled out.

SECTION 4 BATTER IS OUT

ART. 1 . . . A batter is also out as in above penalty or when:

- a. the batter enters the batter's box with an illegal bat (see 1-3-5) or is dis-

- covered having used an illegal bat. If the infraction is discovered before the next pitch following the turn at bat of the player who used an illegal bat, the defense may take the penalty or the result of the play;
- b. a third strike is not caught, provided a runner occupies first base and there are less than two outs;
 - 1. If there are two outs or if no runner occupies first base, the batter is not out unless the third strike is caught. He is entitled to try to reach first base before being tagged out or thrown out.
 - c. a third strike (7-2) is caught;
 - d. a foul ball (other than a foul tip not a third strike) is caught by a fielder or such catch is prevented by a spectator reaching into the playing area (8-3-3e);
 - e. an attempt to bunt on third strike is a foul;
 - f. any member of the offensive team or coach other than the runner(s) interferes with a fielder who is attempting to field a foul fly ball;
 - g. a team playing with one less than the starting number and that turn to bat is reached;
 - h. he enters the game as an illegal substitute and is discovered; or
 - i. he intentionally deflects a foul ball which has a chance of becoming fair.

Rule 8 *Baserunning*

SECTION 1 WHEN BATTER BECOMES A RUNNER

ART. 1 . . . A batter becomes a runner with the right to attempt to score by advancing to first, second, third and home bases in the listed order when:

- a. he hits a fair ball (2-5-1);
 - 1. He becomes a batter-runner when entitled to run.
- b. he is charged with a third strike;
 - 1. If third strike is caught, he is out an instant after he becomes a runner.
- c. an intentional base on balls is awarded, or a fourth ball is called by the umpire;
- d. a pitched ball hits his person or clothing, provided he does not strike at the ball; or
 - 1. If he permits the pitched ball to touch him (7-3-4), or if the umpire calls the pitched ball a strike, the hitting of the batter is disregarded except that the ball is dead. It is a strike or ball depending on location of the pitch.
 - 2. If a batter's loose garment, such as a shirt that is not worn properly, is touched by a pitched ball, the batter is not entitled to first base.
- e. the catcher or any other defensive player obstructs him. The coach or captain of the team at bat, after being informed by the umpire-in-chief of the obstruction, shall indicate whether or not he elects to decline the obstruction penalty and accept the resulting play. Such election shall be

made before the next pitch (legal or illegal), before the award of an intentional base on balls, or before the infielders leave the diamond. Obstruction of the batter is ignored if the batter-runner reaches first and all other runners advance at least one base.

1. Any runner attempting to advance (i.e., steal or squeeze) on a catcher's obstruction of the batter shall be awarded the base he is attempting. If a runner is not attempting to advance on the catcher's obstruction, he shall not be entitled to the next base, if not forced to advance because of the batter being awarded first base. If obstruction is enforced, all other runners on the play will return to base occupied at time of the pitch. The batter is awarded first base, if he did not reach base.
2. If obstruction is not enforced, all other runners advance at their own risk.

ART. 2 . . . A batter-runner is awarded first base if:

- a. he is a runner because of 8-1-1c, d, e; or
- b. his fair ball, other than an infield fly, becomes dead (5-1-1f-1,2) and provided a preceding runner or retired runner does not interfere in such a way as to prevent a potential double play (8-4-1h).

NOTE: Unless awarded first base as above, a batter-runner is entitled to first base only if he reaches it before being tagged out or thrown out or called out for hitting an infield fly (8-4-1).

SECTION 2 TOUCHING, OCCUPYING AND RETURNING TO A BASE

ART. 1 . . . An advancing runner shall touch first, second, third and then home plate in order, including awarded bases.

ART. 2 . . . A returning runner shall retouch the bases in reverse order. If the ball is dead because of an uncaught foul, it is not necessary for a returning runner to retouch intervening bases. The umpire will not make the ball live until the runner returns to the appropriate base.

ART. 3 . . . Any runner who misses a base while advancing may not return to touch it after a following runner has scored.

NOTE: Any runner who misses the first base to which he is advancing and who is later called out shall be considered as having advanced one base.

ART. 4 . . . If a fair or foul batted ball is caught, other than a foul tip, each base runner shall touch his base after the batted ball has touched a fielder. (See 8-4-1c for fielder intentionally dropping the ball and 8-4-2i for runner being put out.)

ART. 5 . . . If a runner who misses any base (including home plate) or leaves a base too early, desires to return to touch the base, he must do so immediately. If the ball becomes dead and the runner is on or beyond a succeeding base, he cannot return to the missed base and, therefore, is subject to being declared out upon proper and successful appeal.

PENALTY (ART. 1-5): For failure to touch a base (advancing and returning), or failure to tag up as soon as the ball is touched on a caught fly ball, the runner may be called out if an appeal is made by the defensive team. The defense may appeal during a live ball immediately following the play and before a

pitch (legal or illegal), granting an intentional base on balls, or before the next play or attempted play. If the offensive team initiates a play before the next pitch, the defensive team does not lose the right to appeal. A live-ball appeal may be made by a defensive player with the ball in his possession by tagging the runner or touching the base that was missed or left too early. A dead-ball appeal may be made by a coach or any defensive player with or without the ball by verbally stating that the runner missed the base or left the base too early. Appeals must be made (1) before the next legal or illegal pitch; (2) at the end of an inning, before the pitcher and all infielders have left fair territory; (3) before an intentional base on balls is granted; or (4) on the last play of the game, an appeal can be made until the umpires leave the field of play. NOTE: When a play by its very nature is imminent and is obvious to the offense, defense and umpire(s), no verbal appeal is necessary, e.g. runner attempting to retouch a base that was missed, or a failure to tag up and a throw has been made to that base or plate while a play is in progress.

ART. 6 . . . Appeal procedures and guidelines

a. Types

1. Missing a base
 2. Leaving a base on a caught fly ball before the ball is first touched.
- b. **Live Ball.** In all games an appeal may be made during a live ball by any fielder in possession of the ball touching the base missed or left too soon on a caught fly ball, or by tagging the runner committing the violation if he is still on the playing field.
- c. **Dead Ball.** The dead-ball appeal may be made: 1) Once all runners have completed their advancement and time has been called, a coach or any defensive player, with or without the ball, may make a verbal appeal on a runner missing a base or leaving a base too soon on a caught fly ball. The administering umpire should then make a decision on the play. 2) If the ball has gone out of play, runners must be given the opportunity to complete their base-running responsibilities before the dead-ball appeal can be made.
- d. **May Not Return.** A runner may not return to touch a missed base or one left too soon on a caught fly ball if:
1. he has reached a base beyond the base missed or left too soon and the ball becomes dead,
 2. he has left the field of play, or
 3. a following runner has scored.
- e. **Advance.** Runners may advance during a live-ball appeal play. If a time out is requested for an appeal, the umpire should grant it, and runners may not advance until the ball becomes live again.
- f. **More Than One Appeal.** Multiple appeals are permitted as long as they do not become a travesty of the game.
- g. **Awards.** An appeal must be honored even if the base missed was before or after an award.

- h. **Tag-Ups.** If a runner leaves a base too soon on a caught fly ball and returns in an attempt to retag, this is considered a time play and not a force out. If the appeal is the third out, all runs scored by runners in advance of the appealed runner and scored ahead of the legal appeal would count.
- i. **Fourth-Out Appeal.** An appeal may be made after the third out as long as it is made properly and the resulting appeal is an apparent fourth out.
- j. **End of Game.** If any situation arises which could lead to an appeal by the defense on the last play of the game, the appeal must be made while an umpire is still on the field of play.
- k. **Third-out Baserunning Infraction.** If a baserunning infraction is the third out, runs scored by the following runner(s) would not count. With two outs, if the base missed was the first to which the batter or runner was forced to advance, no runs would score. When a runner is legally returning after a fly ball has been caught, he can be put out by being tagged with the ball by a defensive player or merely by the defensive player with the ball touching the base occupied by the runner at the time of the pitch.
- l. **Last Time By.** If a runner correctly touches a base that was missed (either in advancing or returning), the last time he was by the base, that last touch corrects any previous baserunning infraction.

ART. 7 . . . A batter-runner who reaches first base safely and then overruns or overslides may immediately return without liability of being put out provided he does not attempt or feint an advance to second. A player who is awarded first base on a base on balls does not have this right.

ART. 8 . . . A runner acquires the right to the proper unoccupied base if he touches it before he is out. He is then entitled to this base until he is put out, or until he legally touches the next base while it is unoccupied or until a following runner is forced (2-24-1) to advance to the base he has occupied. A runner need not vacate his base to permit a fielder to catch a fly ball in the infield, but he may not interfere.

- a. If two runners are on the same base, at the same time and both are tagged, the following runner is declared out. On a force play situation, the runner who is forced to advance shall be declared out when tagged on the base or the base to which he is forced is touched by a fielder while in possession of the ball.

ART. 9 . . . Each runner shall touch his base after the ball becomes dead. All awarded bases must be touched in their proper order. The runner returns to the base he had reached or passed when the ball became dead. In the event of interference, a runner returns to the base he had legally reached at the time of the interference. If the interference does not cause the batter to be out and any other runner cannot return to the base last legally occupied at the time of the interference, he is advanced to the next base.

- a. The runner returns to the base occupied at the time of the pitch if his advance was during an uncaught foul.

BASERUNNING AWARDS TABLE

NO. BASES AWARDED	DETERMINED FROM BASE OCCUPIED AT TIME OF:
ONE BASE (runners)	
1. Balk	1. Infraction
2. Pitch from pitcher's plate thrown out of play	2. Pitch
3. Throw from pitcher's plate goes out of play	3. Throw
4. Unintentional catch and carry	4. Pitch
5. *Catcher obstruction (if attempting to advance)	5. Pitch
6. Forced (because batter is awarded 1st base)	6. Pitch
7. Pitch strikes runner	7. Pitch
ONE BASE (batter)	
1. Walk	1. Pitch
2. Pitch thrown out of play on ball four	2. Pitch
3. *Batter is obstructed	3. Pitch
4. Hit by pitch	4. Pitch
5. Runner interference (unintentional)	5. Pitch
6. Umpire interference (hit by batted ball)	6. Pitch
7. Pitch lodges in defensive player's or umpire's uniform or equipment on ball four	7. Pitch
TWO BASES (batter and runners)	
1. Fair batted ball bounces over, through, goes under, lodges in or under fence	1. Pitch
2. #Fair batted ball or thrown ball lodges in defensive player's or umpire's uniform or equipment	2. Pitch
3. *#Live thrown ball or pitch touched by illegal glove or mitt	3. Infraction
4. *#Live thrown ball or pitch touched by detached player equipment which is thrown, tossed, kicked or held by fielder	4. Infraction
5. First throw by infielder and ball goes out of play or lodged in or under fence	5. Pitch
6. For any subsequent play by an infielder or for any throw by an outfielder and ball goes out of play or lodges in or under fence.	6. Throw
7. Intentional catch and carry (runners only)	7. Pitch
THREE BASES (batter and runners)	
1. Fair batted ball contacted with detached player equipment or illegal glove/mitt	1. Infraction
FOUR BASES (batter and runners)	
1. Fair batted ball over fence in flight	1. Pitch
2. Fair batted ball hits foul pole above fence in flight	2. Pitch
3. Fair batted ball prevented from going over fence because it is touched by spectator	3. Pitch
4. Fair batted ball prevented from going over fence because of contact with detached player equipment or illegal glove/mitt	4. Pitch
UMPIRE JUDGMENT	
1. Spectator interference	1. Infraction
2. *Runner(s) obstruction (minimum of one base)	2. Infraction
3. Defensive malicious contact	3. Infraction

*Award only if infraction is not ignored

#An award to the batter-runner on a pitch is only made if he has the right to advance to first base.

SECTION 3 BASERUNNING AWARDS

ART. 1 . . . Each runner other than the batter-runner (who is governed by 8-1-2) is awarded one base when:

- a. there is a balk (5-1-1a, 6-2-4) or a pitch strikes a runner (6-1-4);
- b. he is forced from the base he occupies by a following runner who must advance because a batter receives a fourth ball, or is hit by a pitched ball, or hits a fair ball which becomes dead (5-1-1f,g);
- c. he is attempting to steal or he is forced from the base he occupies by a batter-runner or runner who must advance because the catcher or any fielder obstructs the batter, such as stepping on or across home or pushing the batter to reach the pitch or touching the bat (8-1-1e). Instances may occur when the infraction may be ignored (8-1-1e).

ART. 2 . . . When a runner is obstructed (2-22) while advancing or returning to a base, the umpire shall award the obstructed runner and each other runner affected by the obstruction the bases they would have reached, in his opinion, had there been no obstruction. If the runner achieves the base he was attempting to acquire, then the obstruction is ignored. The obstructed runner is awarded a minimum of one base beyond his position on base when the obstruction occurred. If any preceding runner is forced to advance by the awarding of a base or bases to an obstructed runner, the umpire shall award this preceding runner the necessary base or bases. Malicious contact supersedes obstruction. Runner(s) will be awarded appropriate base(s) per umpire judgement. When obstruction occurs, the umpire gives the delayed dead ball signal and calls "obstruction." If an award is to be made, the ball becomes dead when time is taken to make the award.

ART. 3 . . . Each runner is awarded:

- a. four bases (home) if a fair ball goes over a fence in flight or hits a foul pole above the fence, or is prevented from going over by being touched by a spectator, or is touched by an illegal glove/mitt or detached player equipment which is thrown, tossed, kicked or held by a fielder;
- b. three bases if a batted ball (other than in item a) is touched by an illegal glove or mitt, or by detached player equipment which is thrown, tossed, kicked or held by a fielder, provided the ball when touched is on or over fair ground, or is a fair ball while on or over foul ground, or is over foul ground in a situation such that it might become a fair ball;
- c. two bases if a fair batted or thrown ball becomes dead because of bouncing over or passing through a fence, or lodges in a defensive player's or umpire's equipment or uniform; or if a live thrown ball:
 1. including a pitch, is touched by an illegal glove or mitt, or by detached player equipment which is thrown, tossed, kicked or held by a fielder; or
 2. goes into a stand for spectators, dugout or player's bench or over or through or lodges in a fence and it is not thrown by a pitcher from his plate as in 8-3-3d;

3. When two runners are between the same bases on an overthrow into dead ball territory, the lead runner receives two bases and the following runner is awarded one, since both runners cannot share the same awarded base.
 4. Runners between second and third would score, because the award does not result in both runners occupying the same base.
- d. one base if a pitch or any throw by the pitcher from his pitching position on his plate goes into a stand or bench or over or through or lodges in a fence or backstop or touches a spectator or lodges in an umpire's or catcher's equipment; or with less than two outs, the batter hits a fair or foul ball (fly or line drive) which is caught by a fielder, who then leaves the field of play by stepping with both feet or by falling into a bench, dugout, stand, bleacher or over any boundary or barrier such as a fence, rope, chalk line or pre-game determined imaginary boundary line. A runner shall not be declared out if the fielder deliberately throws or carries the ball into dead ball territory to prevent that runner who has touched or advanced beyond a succeeding base from returning to a missed base or a base left too soon. Award the runner two bases. This allows the runner(s) to correct any base-running error. Defense may still appeal the play.
 - e. bases as determined by the umpire, who shall also impose such penalties as in his judgment will nullify the act of spectator interference with any thrown or batted ball. The ball shall become dead at the moment of the interference (8-3-3a, b, c, d). It is not spectator interference if a spectator physically hinders a fielder who is reaching into a dead ball area to make a play on a batted or thrown ball.
 - f. one base beyond the last legally acquired base, if in the umpire's judgment the runner was attempting to advance at the time the ball becomes lodged in an offensive player's uniform or equipment. If the lodged ball occurs during play when the batter-runner was attempting to reach first base, the batter-runner will be awarded first base. Preceding runners will be awarded bases needed to complete the award.

ART. 4 . . . Illegal use of detached player equipment (8-3-3a, b and c) or an illegal glove/mitt does not cause ball to immediately become dead. If each runner advances to or beyond the base which he would reach as a result of the award, the infraction is ignored. Any runner who advances beyond the base he would be awarded does so at his own risk and may be put out.

ART. 5 . . . An award is from the base determined as follows:

- a. If the award is the penalty for an infraction such as a balk, use of detached player equipment, or an illegal glove/mitt, the award is from the base occupied at the time of the infraction.
- b. If any pitch (batted or unbatted) is followed by a dead ball before the pitcher is in position for the next pitch and before there is any throw by the fielding team, any award is from the base occupied at the time of the pitch.

When a runner, who is returning to touch a base after a batted ball has been caught is prevented from doing so because a thrown live ball has become dead

(5-1-1g), his award shall be from the base he occupied at the time of the pitch. In any situations other than (a) or (b), on a batted ball which is the first play by an infielder, all runners including the batter-runner are awarded two bases from their positions at the time of the pitch. For purposes of this rule, the act of fielding is not considered a play. If every runner, including the batter-runner, has advanced one base at the time of the first play, the award is two bases from the time of the throw. For any subsequent play by an infielder or for any throw by an outfielder, the award is two bases from the time of the throw.

SECTION 4 RUNNER IS OUT

ART. 1 . . . The batter-runner is out when:

- a. he intentionally interferes with the catcher's attempt to field the ball after a third strike;
- b. his fair hit or foul (other than a foul tip which is not a third strike) is caught by a fielder, or such catch is prevented by a spectator reaching into the playing field;
- c. his fair fly, fair line drive or fair bunt in flight is intentionally dropped by an infielder with at least first base occupied and before there are two outs. The ball is dead and the runner or runners shall return to their respective base(s).
 1. In this situation, the batter is not out if the infielder permits the fair fly, fair line drive or fair bunt in flight to drop untouched to the ground, except when the infield fly rule (2-19) applies (5-1-1j).
- d. after hitting or bunting a ball, he intentionally contacts the ball with the bat a second time in fair or foul territory. The ball is dead and no runner(s) advance.
 1. In the case of a foul ball, it must have a chance to become fair in the umpire's judgment.
 2. If the bat and ball accidentally come in contact with each other a second time while the batter is holding the bat in the batter's box, it is a foul ball.
- e. a third strike is caught by the catcher; or the third strike is not caught with first base occupied and there are less than two outs (2-16-2);
- f. after a dropped third strike (see 8-4-1e) or a fair hit, if the ball held by any fielder touches the batter before the batter touches first base; or if any fielder, while holding the ball in his grasp, touches first base or touches first base with the ball before the batter-runner touches first base; or
- g. he runs outside the three-foot running lane (last half of the distance from home plate to first base), while the ball is being fielded or thrown to first base; or
 1. This infraction is ignored if it is to avoid a fielder who is attempting to field the batted ball or if the act does not interfere with a fielder or a throw.
 2. The batter runner is considered outside the running lane lines if either foot is outside either line.

- h. any runner or retired runner interferes (2-21-1, 2-30-3) in a way which obviously hinders an obvious double play; or
- i. on a dropped third strike, he gives up by entering the bench or dugout area, or with two outs he does not attempt to reach first base before all infielders leave the diamond at the end of the half-inning;
- j. hits an infield fly and the infield-fly rule is in effect;
- k. enters the game as an illegal substitute and is discovered.

ART. 2 . . . Any runner is out when he:

- a. runs more than three feet away from a direct line between bases to avoid being tagged or to hinder a fielder while the runner is advancing or returning to a base;
 - 1. This is not an infraction if a fielder attempting to field a batted ball is in the runner's proper path and if the runner runs behind the fielder to avoid interfering with him.
 - 2. When a play is being made on a runner or batter-runner, he establishes his baseline as directly between his position and the base toward which he is moving.
- b. does not legally slide and causes illegal contact and/or illegally alters the actions of a fielder in the immediate act of making a play, or on a force play, does not slide in a direct line between the bases; or
 - 1. A runner may slide in a direction away from the fielder to avoid making contact or altering the play of the fielder.
 - 2. Runners are never required to slide, but if a runner elects to slide, the slide must be legal. (2-32-1, 2) Jumping, hurdling, and leaping are all legal attempts to avoid a fielder as long as the fielder is lying on the ground. Diving over a fielder is illegal.

PENALTY: The runner is out. Interference is called and the ball is dead immediately. On a force-play slide with less than two outs, the runner is declared out, as well as the batter-runner. Runners shall return to the bases occupied at the time of the pitch. With two outs, the runner is declared out. The batter is credited with a fielder's choice.

- c. does not legally attempt to avoid a fielder in the immediate act of making a play on him; or

PENALTY: The runner is out, the ball remains live unless interference is called.

- d. dives over a fielder; or

PENALTY: The runner is out and the ball remains live unless interference occurs and is declared.

- e. initiates malicious contact;
 - 1. Malicious contact always supersedes obstruction. Runner(s) will be awarded appropriate base(s) per umpire's judgment.
- f. as a runner or retired runner, fails to execute a legal slide, or does not attempt to avoid the fielder or the play on a force play at any base; or
- g. intentionally interferes with a throw or a thrown ball; or he hinders a fielder on his initial attempt to field a batted ball. A fielder is not protected,

except from intentional contact if he misplay the ball and has to move from his original location; or his being put out is prevented by an illegal act by anyone connected with the team (2-21-1, 3-2-2, 3) or by the batter-runner; for runner returning to base (8-2-6); and for runner being hit by a batted ball (8-4-2k). If, in the judgment of the umpire, a runner including the batter-runner interferes in any way and prevents a double play anywhere, two shall be declared out (the runner who interfered and the other runner involved). If a retired runner interferes, and in the judgment of the umpire, another runner could have been put out, the umpire shall declare that runner out. If the umpire is uncertain who would have been played on, the runner closest to home shall be called out; or

1. If two fielders try to field a batted ball and the runner contacts one or both, the umpire shall decide which one is entitled to field the ball and that fielder only is entitled to protection. If a fielder drops a batted ball and contact with a runner occurs during a subsequent attempt to field the ball, the fielder has the greater responsibility for avoiding contact.
- h. is touched by a live ball securely held by a fielder or is touched by a fielder's glove or hand with the live ball held therein, while the runner is not touching his base.
1. If a batter-runner safely touches first base and then overslides or overruns it, except on a base on balls, he may immediately return to first base without liability of being tagged out, provided he did not attempt to run or feint to second. Also, if any base comes loose from its fastening when any runner contacts it, such runner cannot be tagged out because the base slides away from him.
 2. The ball is not securely held if it is dropped or juggled after the runner is touched.
- i. does not retouch his base before a fielder tags him out or holds the ball while touching such base after any situation (8-2-1, 2-3 and 4). Umpire may also call him out at end of playing action upon proper and successful appeal. Also, it is not necessary for runner to retouch his base after a foul tip (2-16-2); or
- j. fails to reach the next base before a fielder either tags the runner out or holds the ball while touching such base, after runner has been forced from the base he occupied because the batter became a runner (with ball in play) when other runners were on first base, or on first and second, or on first, second and third. There shall be no accidental appeals on a force play.
1. No runner may be forced out if a runner who follows him in the batting order is first put out (including a batter-runner who is out for an infield fly).
- k. is contacted by a fair batted ball before it touches an infielder, or after it passes any infielder, except the pitcher, and the umpire is convinced that another infielder has a play (5-1-1f, 6-1-5).
1. If a runner is touching his base when he is hit by an infield fly, he is not out, but the batter is out by the infield fly rule. The ball is dead, even in the exception.

2. If a runner is hit by an infield fly when he is not touching his base, both he and the batter are out.
 - l. attempts to advance to home base when the batter interferes with a play at home base, with less than two outs; or
 1. If there are two outs, the batter is out because of his interference and since he is the third out, the runner cannot score. But if there are not two outs, the runner is out and the batter is not penalized.
 - m. passes an unobstructed preceding runner before such runner is out (including awarded bases); or
 - n. runs bases in reverse to confuse opponents to make a travesty of the game; or
 - o. positions himself behind a base to get a running start; or
 - p. after at least touching first base, leaves the baseline, obviously abandoning his effort to touch the next base; or
- NOTE:** Any runner, after reaching first base, who leaves the baseline heading for the dugout or his defensive position believing that there is no further play, shall be declared out if the umpire judges the act of the runner to be considered abandoning his efforts to run the bases.
- q. is on or beyond a succeeding base when the ball is declared dead (5-2-2b-1) after having left a base too soon on a caught fly ball, or he failed to touch a preceding base, or he continues and touches a succeeding base after the ball has become dead and the defense initiates a proper and successful appeal;
 - r. deliberately knocks the ball from a fielder's hand.

Rule **9** Scoring — Record Keeping

SECTION 1 HOW A TEAM SCORES

ART. 1 . . . A runner scores one run each time he legally advances to and touches first, second, third and then home plate before there are three outs to end the inning.

EXCEPTION: A run is not scored if the runner advances to home plate during action in which the third out is made as follows:

- a. by the batter-runner before he touches first base; or
- b. by another runner being forced out; or
- c. by a preceding runner who is declared out upon appeal because he failed to touch one of the bases or left a base too soon on a caught fly ball; or
- d. when a third out is declared during a play resulting from a valid defensive appeal, which results in a force out (this out takes precedence if enforcement of it would negate a score); or
- e. when there is more than one out declared by the umpire which terminates the half inning, the defensive team may select the out which is to its advantage as in 2-20-2. Credit the putout to the nearest designated baseman.

EXAMPLE: If second base is involved, credit the second baseman with the putout.

NOTES:

1. If a fielder illegally obstructs a runner and is responsible for failure of that runner to reach home plate, the umpire has authority to award home plate to that runner.
2. When the winning run is scored in the last half inning of a regulation game, or in the last half of an extra inning, as the result of a base on balls, hit batter or any other play with the bases loaded which forces the runner on third base to advance, the umpire shall not declare the game over until all runners have advanced to the next base.

ART. 2 . . . The number of runs scored by each team is entered in the scorebook for each inning. The team whose runners score the greatest total number of runs for the entire regulation game is the winner (4-2).

SECTION 2 RECORDING GAME ACTIVITY

ART. 1 . . . Uniformity in records of game activity is promoted by use of a standard tabulation sheet containing columns as shown in the diagram below.

ART. 2 . . . The official scorer shall keep records as outlined in the following rules. He or she has the final authority when judgment is involved in determining whether a batter-runner's advance to first base is the result of an error or of a base hit. The scorebook of the home team shall be the official scorebook, unless the umpire-in-chief rules otherwise.

SECTION 3 PLAYER'S BATTING RECORD

ART. 1 . . . Each player's batting record shall include:

- a. in columns 1, 2 and 3 after name and position, the number of times he batted (2-39-1), the runs he scored (9-1-1), and the base hits he made (9-3-2);
- b. in the summary, the number of total base hits and the type (single, double, triple or home run), sacrifices, and number of runs he batted in;

VISITOR: St. Victor			COACH: Beddow			RECORD			SCORER: White			FINAL: 8-0										
PD	A	E	NO	PLAYER	1	2	3	4	5	6	7	8	9	10	AB	R	H	BB	SO	SA	CS	PT
			7	Hopkins, S.	3										5	2	4	1	1			
			3	Ondrovic, M.	5										5	1	3					1
			4	McNealy, K.	4										5	1	2					1
			6	Brewer, G.	2										5	2						2
			8	Holman, R.	1										5	1	2	4				1
			10	Antle, H.	6										5	1	3					2
			9	Cousins, M.	7										4	1	1					
			40	Healy, C.	8										4	1	3					1
			1	Cook, D.	9										4	0	0					2
SCORING SUMMARY					H	0	2	0	4	6	0	2	4	4	0	3						

- c. slugging percentage, which is total bases (i.e., double = two bases, triple = three bases, etc.) divided by official at bats; and
- d. on-base percentage, which is the number of hits, walks and hit by pitch divided by the number of official at-bats, walks, hit by pitch and sacrifice flies).

ART. 2 . . . A base hit is credited to a batter when he advances to first base safely:

- a. because of his fair hit (rather than because of a fielder's error);
 - 1. It is not a base hit if any runner is out on a force play caused by the batter advancing toward first base.
 - 2. Base hits include any fair hit which cannot be fielded in time to throw out or tag out a batter-runner or any other runner when he is being forced to advance. Illustrations are: ball is stopped or checked by a fielder in motion who cannot recover in time, or ball moves too slowly; or ball is hit with such force to a fielder that neither he nor an assisting fielder can handle it.
- b. without liability of being put out because: a runner is declared out for being hit by the batted ball (8-4-2k), or the umpire is hit by a batted ball (8-1-2b), or
- c. because of a fielder's choice (2-14-1) when a fielder attempts to put out another runner but is unsuccessful and the scorer believes the batter-runner would have reached first base even with perfect fielding.

ART. 3 . . . A base hit for extra bases is credited to the batter when it is the sole reason for his safe arrival at second (double), third (triple) or home base (home run).

ART. 4 . . . A sacrifice is credited to the batter when, with not more than one out, his bunt enables any runner to advance or his fly ball enables a runner to score but which, in either case, results in the batter-runner being out before he reaches first, or would have resulted in his being put out if his bunt or batted ball had been fielded without error.

ART. 5 . . . A run batted in is credited to the batter when a runner scores because of a base hit, including the batter-runner's score on a home run; a sacrifice; any putout; a forced advance, such as for a base on balls or batter being hit; or an error, provided there are not two outs and that action is such that the runner on third would have scored even if there had been no error.

- a. It is not a run batted in if there is a double play from a force or one in which the batter is put out or should have been put out on a batted ground ball.

ART. 6 . . . When a strikeout involves more than one batter, it is charged to the one who received at least two strikes. If no batter received more than one strike, it is charged to the batter who received the third strike.

SECTION 4 PLAYER'S BASERUNNING RECORD

ART. 1 . . . A stolen base shall be credited in the summary to a runner each time he advances a base without the aid of a base hit, a putout, a fielding (includ-

ing battery) error or fielder's choice.

EXCEPTION: No runner is credited with a steal if:

- a. after reaching the base, the runner overslides and is put out; or
- b. in an attempted double or triple steal, any runner is put out; or
- c. opponents are in collusion as in a deliberate attempt to help establish a record; or
- d. there is defensive indifference and no play is attempted.

SECTION 5 PLAYER'S FIELDING RECORD

ART. 1 . . . Each player's fielding record shall include the times he put out a batter or runner, the times he assisted a teammate in putting out a runner, and the number of errors he committed. These shall be recorded respectively in columns 4, 5, and 6.

ART. 2 . . . A putout is credited to a fielder who catches a batted ball in flight, or who tags out a runner, or who puts out a runner by holding the ball while touching a base to which a runner is forced to advance or return.

EXCEPTIONS:

1. Catcher is credited with the putout when batter is out for illegally batting the ball, for a third strike bunted foul, for being hit by his own batted ball, for batting out of turn or for batter's interference.
2. For an infield fly, the putout is credited to the fielder who would ordinarily have made the catch.
3. For runner being out because of being hit by a batted ball, the putout is credited to the fielder who is nearest the ball at the time.
4. For runner called out for missing base, credit putout to fielder at that base.
5. For malicious contact by a runner, credit the putout to the involved fielder.

ART. 3 . . . An assist is credited to a fielder each time he handles or deflects the ball during action which is connected with the putout or he handles the ball prior to an error which prevents what would have been a putout. If several fielders handle the ball or one fielder handles it more than once during a play, such as when a runner is caught between bases, only one assist is credited to each of such fielders.

- a. After a pitch, if catcher tags out or throws out a runner, the pitcher is not credited with an assist.

ART. 4 . . . A double play or triple play is credited to one or more fielders when two or three players are put out between the time a pitch is delivered and the time the ball next becomes dead or is next in possession of the pitcher in pitching position.

ART. 5 . . . An error is charged against a fielder or a team for each misplay that prolongs the time at bat of the batter or the time a player continues to be a runner, or permits the runner to advance one or more bases.

EXCEPTIONS:

1. A pitcher is not charged with an error for a base on balls; or a batter being hit, or a balk, or a wild pitch.
2. A catcher is not charged with an error for a wild throw in his attempt to prevent a stolen

base unless the runner advances another base because of the wild throw.

3. Neither catcher nor infielder is charged with an error for a wild throw in an attempt to complete a double play, unless the throw is so wild that it permits a runner to advance an additional base. But if a player drops a thrown ball, when by holding it he would have completed the double (or triple) play, it is an error. A passed ball is a pitch the catcher fails to stop or control when he should have been able to do so with ordinary effort and on which a runner, other than the batter, is able to advance. When a passed ball occurs on a third strike, permitting a batter to reach first base, score a strikeout and a passed ball.

4. A fielder is not charged with an error for accurately throwing to a base whose baseman fails to stop or try to stop the ball, provided there was good reason for the throw. If the runner advances because of the throw, the error is charged to the team or fielder who should have covered that base.

5. If a fielder drops a fair fly ball but recovers in time to force out a runner, he is not charged with an error. It is recorded as a force-out.

SECTION 6 PITCHER'S RECORD

ART. 1 . . . A wild pitch shall be charged in the summary to the pitcher when a ball legally delivered to the batter is so high, or so low (including any pitch that touches the ground in front of home plate), or so far away from home plate that the catcher does not stop or control it with ordinary effort so that the batter-runner advances to first base or any runner advances a base. When the catcher enables a runner, other than the batter-runner, to advance by failing to control a pitch that he should have been able to control, it is not a wild pitch but a "passed ball."

ART. 2 . . . The number of bases on balls, batters being hit by a pitch, strikeouts, and base hits allowed by each pitcher shall be recorded in the summary. If batter is hit by what would have been the fourth ball, it is recorded as a hit batter.

ART. 3 . . . In order for a run to be earned, it must be scored without the aid of errors, or passed balls. To determine whether runs are earned or not, reconstruct the inning without the errors and passed balls. If there is doubt as to whether or not a run is earned, the pitcher shall be given the benefit.

ART. 4 . . . A strikeout is credited to the pitcher when a third strike is delivered to a batter even though the batter might reach first base because the third strike is a wild pitch or is not caught. It is also a strikeout if an attempted third strike bunt is an uncaught foul.

ART. 5 . . . A relief pitcher shall not be charged with any earned run scored by a runner who was on base when such pitcher entered, nor with any hit or advance by a batter who had more balls than strikes when such pitcher entered.

ART. 6 . . . Winning and losing pitchers are determined as follows:

- a. If the starting pitcher has pitched the first four innings or more and his team is ahead when he is replaced and the team holds the lead for the remainder of the game, he shall be the winning pitcher.
- b. If a game ends for whatever reason, having gone less than seven innings,

then the starting pitcher shall have pitched three or more consecutive innings to be declared the winning pitcher. If the starting pitcher cannot be declared the winning pitcher, and more than one relief pitcher is used, the winning pitcher shall be determined using the following criteria:

1. If the score is tied, it results in the game becoming a new contest so far as judging who is the winning and losing pitcher.
 2. If the starting pitcher is removed before having pitched four or more innings and his team is ahead, the official scorer shall determine the winning pitcher to be the relief pitcher who has been the most effective.
 3. If the opposition goes ahead, pitchers up to that time in the game cannot be credited with the win. However, if the pitcher pitching subsequently takes and maintains a lead the remainder of the game, said pitcher is credited with the win.
 4. Generally the relief pitcher credited with the win is the pitcher when his team takes the lead and holds it for the rest of the game. However, if the relief pitcher pitches only a short while or not effectively and a succeeding relief pitcher replaces him and does better work in keeping the lead, the latter shall be granted the win.
- c. If a pitcher is removed for a pinch-hitter or a pinch-runner, the runs scored by his team during the inning of his removal are to be credited to his benefit to decide the pitcher of record.
- d. The starting pitcher shall be charged with the loss when he is replaced and his team is behind or falls behind because of runs assessed to him after being replaced and his team does not subsequently tie the score or take the lead.
- e. A pitcher cannot be given credit for pitching a shutout when he does not pitch the complete game except when he enters the game with no one out before the opponents have scored in the first inning and does not permit the opposition to score during the game.

ART. 7 . . . In order for a pitcher to be credited with a save, he shall meet all three of the following criteria:

- a. he is the last pitcher in a game won by his team; and
- b. he is not the winning pitcher; and
- c. he meets at least one of the following:
 1. he enters the game with a lead of not more than three runs and pitches at least one inning; or
 2. he enters the game regardless of the count on the batter with the potential tying run either on base, at bat or on deck; or
 3. he pitches effectively for at least three innings.
 4. A starting pitcher who is replaced and then re-enters as pitcher can be credited with a win but not a save.

SECTION 7 GENERAL SUMMARY

ART. 1 . . . The game summary includes the following:

- a. Total score and runs scored in each inning.
- b. Stolen bases for each runner.

- c. Sacrifices by each batter.
- d. Base hits by each batter and total against each pitcher.
- e. Two- or three-base hits and home runs.
- f. Times at bat for each player and total against each pitcher.
- g. Strikeouts by each pitcher.
- h. Bases on balls by each pitcher.
- i. Wild pitches by each pitcher.
- j. Times each pitcher hits batter with pitch and names of those hit.
- k. Passed balls by catcher.
- l. Time required to play game and name of each umpire.
- m. Names of winning and losing pitchers.
- n. Name of pitcher to receive credit for a save.

ART. 2 . . . Percentage records are computed as follows:

- a. Percentage of games won and lost — divide the number of games won by total games played.
- b. Batting percentage — divide the total number of base hits, not the total bases on hits, by the total times at bat.
- c. Fielding percentage — divide the total putouts and assists by the total of putouts, assists and errors.
- d. Pitcher's earned run average — divide the total runs earned during his pitching by the total number of innings he pitched and multiply by seven.
 - 1. In items a, b, c or d, if there is a fraction of $\frac{1}{2}$ or more, a full point is added.

Rule 10

Umpiring

SECTION 1 GENERAL

ART. 1 . . . Game officials include the umpire-in-chief and one, two, three or more field umpires. Whenever possible, at least two umpires are recommended. Any umpire has the authority to order a player, coach or team attendant to do or refrain from doing anything that affects the administration of these rules and to enforce prescribed penalties.

ART. 2 . . . Umpire jurisdiction begins upon the umpires arriving at the field (within the confines of the field) and ends when the umpires leave the playing field at the conclusion of the game. The game officials retain clerical authority over the contest through the completion of any reports, including those imposing disqualification, that are responsive to actions occurring while the umpires had jurisdiction. State associations may intercede in the event of unusual incidents after the umpires' jurisdiction has ended or in the event that a game is terminated prior to the conclusion of regulation play.

ART. 3 . . . If there is only one umpire, he has complete jurisdiction in administering the rules and he may take any position he desires, preferably behind the catcher.

ART. 4 . . . Any umpire's decision which involves judgment, such as whether a hit is fair or foul, whether a pitch is a strike or a ball, or whether a runner is safe or out, is final. But if there is reasonable doubt about some decision being in conflict with the rules, the coach or captain may ask that the correct ruling be made. The umpire making the decision may ask another umpire for information before making a final decision. No umpire shall criticize or interfere with another umpire's decision unless asked by the one making it.

- a. The umpire-in-chief sometimes asks for aid from the base umpire when there is a question as to whether a batter's "half swing" is such as to be called a strike. As an aid in deciding, the umpire may note whether the swing carried the barrel of the bat past the body of the batter, but final decision is based on whether the batter actually struck at the ball.

ART. 5 . . . The use of videotape or equipment by game officials for the purpose of making calls or rendering decisions is prohibited.

ART. 6 . . . No umpire may be replaced during a game unless he becomes ill or is injured. His right to disqualify players or to remove nonplayers for objecting to decisions or for unsportsmanlike conduct is absolute. Ejections will be made at the end of playing action.

ART. 7 . . . Casts, splints and braces may be worn, if padded. Umpires may wear prostheses and use mobility devices.

ART. 8 . . . Umpires shall not use tobacco or tobacco-like products on or in the vicinity of the playing field.

ART. 9 . . . Umpires shall wear gray slacks, and navy pullover shirt or state association-adopted shirt.

SECTION 2 UMPIRE-IN-CHIEF

ART. 1 . . . If there are two or more umpires, the umpire-in-chief shall stand behind the catcher. The umpire-in-chief, when behind the plate, shall wear proper safety equipment including, but not limited to, chest protector, face mask, throat guard, plate shoes, shin guards and protective cup (if male). He shall call and count balls and strikes; signal fair balls; call out "Foul Ball," except on a caught foul fly ball, while signaling a foul ball, except on fair/foul situations commonly called by the field umpire(s); and make all decisions on the batter. He shall make all decisions except those commonly reserved for the field umpire.

ART. 2 . . . The umpire-in-chief has sole authority to forfeit a game and has jurisdiction over any rules matters not mentioned in 10-2-1 and not assigned to the field umpire in 10-3.

ART. 3 . . . His duties include those listed in 10-2-1, 2 and the following:

- a. Inspect the condition of the field, receive batting order of both teams, announce special ground rules and formulate such if the two teams cannot agree, designate the official scorer (9-2-2) and see that each player takes his glove and other loose equipment to the bench at the end of his term in the field.

- b. Call "Play" and use the correct hand signal to start the game or to resume play; and call "Time" whenever ball becomes dead.
- c. Eject a player or coach or clear the bench or send a coach from the field or restrict a coach or player (illegal substitution) to the bench/dugout if it becomes necessary.
- d. Announce each substitution.
- e. Call game if conditions become unfit for play.
- f. Penalize for rule infractions, such as balk, interference, baserunning infractions, delay, unwarranted disputing of decision, or unsportsmanlike conduct.
- g. Make final decision on points not covered by the rules.
- h. Forfeit the game for prescribed infractions by spectators, coaches, players or attendants.
- i. When game is played under the auspices of an organization which permits protests to be filed, he shall report the protest to the organization along with all related conditions at the time of the protested play, provided the protest is brought to the attention of an umpire by the offended team at the time of the play and before the next pitch after such play, or before the umpires leave the field if the play in question is the last play of the game. The umpire-in-chief shall then inform the coach of the opposing team and the official scorekeeper.
 - 1. If there is a question about a rule that was possibly misapplied, the team's coach or captain shall inform the umpire at time of the play and before a pitch to the next batter of either team, or before the umpires leave the field if the play in question was the last play of the game.
- j. Keep a written record of defensive and offensive team charged conferences for each team and notify the respective coach each time a conference is charged to his team. He shall also be responsible for keeping a lineup card and recording all substitutes, courtesy runner participation, and team warnings (1-1-5, 3-4-1, Courtesy Runner Rule #6).
- k. Prohibit any player who exhibits signs, symptoms or behaviors consistent with a concussion (such as loss of consciousness, headache, dizziness, confusion or balance problems) from returning to play until cleared by an appropriate health-care professional.
- l. Rectify any situation in which an umpire's decision that was reversed has placed either team at a disadvantage.
- m. Correct a scorekeeping error if brought to an umpire's attention before the umpires leave the field when the game is over.
- n. Order the lights turned on whenever he believes darkness could make further play hazardous. Whenever possible, lights should be turned on at the beginning of an inning.

SECTION 3 FIELD UMPIRE

ART. 1 . . . A field umpire shall aid the umpire-in-chief in administering the rules. He shall make all decisions on the bases except those reserved for the

umpire-in-chief. He shall have concurrent jurisdiction with the umpire-in-chief in calling time, balks, infield fly, defacement or discoloration of ball by the pitcher, illegal pitches, when a fly ball is caught, or in ejecting any coach or player for flagrant, unsportsmanlike conduct or infraction as prescribed by the rules. In some instances, he will rule on the ball being fair or foul.

ART. 2 . . . When there is only one field umpire, he shall make all calls primarily at first, second and third unless the calls are more conveniently made by the umpire-in-chief.

ART. 3 . . . If additional field umpires are used, they are referred to as base umpires and their normal positions are behind third and second bases. They have concurrent jurisdiction with the first field umpire.

SUGGESTED SPEED-UP RULES

By state association adoption any, all, or any part of the suggested speed-up rules may be used.

COURTESY RUNNERS

1. At any time, the team at bat may use courtesy runners for the pitcher and/or the catcher.
2. The same individual runner may not be used for both positions (pitcher and catcher) during the game.
3. Neither the pitcher nor the catcher will be required to leave the game under such circumstances.
4. Players who have participated in the game in any other capacity are ineligible to serve as courtesy runners.
5. A player may not run as a courtesy runner for the pitcher or the catcher and then be used as a substitute for another player in that half inning. If an injury, illness or ejection occurs and no other runners are available, the courtesy runner may be used as a substitute.
6. The umpire-in-chief shall record courtesy runner participation and also announce it to the scorer.
7. A player who violates the courtesy-runner rule is considered to be an illegal substitute.
 - a. Should an injury, illness or ejection occur to the courtesy runner, another courtesy runner for the pitcher or catcher may run.

AFTER PUTOUTS

1. After a putout in the outfield and with no runners on base, the ball shall be thrown to a cutoff man and, if desired, to one additional infielder before being returned to the pitcher for delivery to the next batter.
2. After a putout in the infield and with no runners on base, the ball shall be returned directly to the pitcher.
3. Following the final out in any inning, the ball shall be given to the nearest

umpire. The plate umpire shall give the ball to the catcher. The base umpire shall place the ball on the pitcher's plate.

SUGGESTED DOUBLE FIRST BASE RULES

1. Runner should use the colored base on initial play at first base (dropped third strike only), unless the fielder is drawn to the side of the colored base (dropped third strike only), in which case the runner would go the white base and the fielder to the colored base.
2. On a dropped third strike, fielder and runner may touch white or colored base.
3. A runner is never out for touching the white base rather than the colored base.
4. Once the runner reaches first base, the runner shall then use the white base.

POINTS OF EMPHASIS

The NFHS Baseball Rules Committee and the NFHS Board of Directors believes there are areas of the game of interscholastic baseball that need to be addressed and given special attention. These areas of concern are often cyclical, some areas need more attention than others, and that is why they might appear in the rules book for consecutive editions. These concerns are identified as "Points of Emphasis." For the 2012 high school baseball season, attention is being called to: coach's responsibility, altering bats, pace of the game, and good sporting behavior. When a topic is included in the Points of Emphasis, these topics are important enough to reinforce or they are not being given the proper attention.

COACH'S RESPONSIBILITY

The role of the head coach is not only very prominent in the community but bears tremendous responsibility. As highlighted in this year's rules changes, the head coach is responsible for being a teacher, role model and mentor. He is required to know and verify that each team member is properly attired and has equipment that meets the standards set by NFHS rules. Besides being the only coach responsible for communications with umpires, he is responsible for appropriate behavior-modeling before, during and after a contest. Everyone involved understands the importance of the role of the coach and the awesome opportunity he has to teach life lessons to willing and capable young people.

ALTERING OF BATS

Altering bats by such methods as rolling, shaving the bat wall, flattening or otherwise manipulating the bat from its original manufactured condition is a federal offense. Not only is it illegal but it can cause injury or worse to a young person. There is a national campaign on not cheating by altering bats in collaboration with the Sporting Goods Manufacturers Association (SGMA) and the NFHS. In

addition, coaches must diligently monitor the condition of the bats and other equipment that is being used by members of the team.

Coaches must ensure that bats purchased for the 2012 season meet the new Batted Ball Coefficient of Restitution performance standard (BBCOR). Due to the fact that many players (and parents) purchase their own bats, it is critical that coaches inform players and parents of the upcoming rule change.

Coaches must insist that players use only legal equipment not only because it is a rule, but it is in the best interest of the principles of fair play and sportsmanship.

PACE OF GAME PLAY

The committee is concerned that long delays in game action detract from what otherwise is an exciting and enjoyable game. There are several rules that need to be enforced more consistently. In particular, the batter's box rule (the batter must generally keep one foot in the box during an at-bat), handling offensive and defensive charged conferences in a timely manner, and speeding the time between innings and during pitching changes by umpires diligently counting the number of warm-up pitches are areas the committee identified as areas in need of improvement.

GOOD SPORTING BEHAVIOR

Coaches and umpires must work together. Each contest is another opportunity for coaches and umpires to teach not only baseball skills, but also model respectful behavior as well as professional relationships. The positive values that are learned will serve the players long after their baseball experience has concluded. Game situations typically provide a coach the opportunity to identify a teachable moment to reinforce good sporting behavior.

RULES BY STATE ASSOCIATION ADOPTION

1-4-4 — To allow for special occasions, commemorative or memorial patches, that will be uniformly placed, not to exceed 4 square inches, to be worn on jerseys in an appropriate and dignified manner without compromising the integrity of the uniform.

1-2-9 — A double first base is permitted.

2-33-1 — Suggested speed-up rules.

4-2-2 — By state association adoption, the game shall end when the visiting team is behind 10 or more runs after 4½ innings, or after the fifth inning, if either team is 10 runs behind and both teams have had an equal number of times at bat.

4-2-4 — Game-ending procedures may be determined.

4-3-1 — A regulation called game where a winner cannot be determined shall be counted as ½ game won and ½ game lost for each team.

4-4-1a — State associations are authorized to specify the time frame and/or circumstances before a forfeit shall be declared for a late arrival by one of the teams.

4-5-1 — It is optional on the part of the state association as to whether protests are permitted.

10-1-9 — Umpires shall wear the navy blue pullover shirt or state association-adopted shirt.

MAJOR RULES DIFFERENCES

NFHS baseball rules are basically the same as professional rules. However, there are differences. Some differences are related to minimizing the risk of injury. Other rules differences apply to philosophy, level of play and ease of administration. Listed below are some of the major rules differences.

NFHS Rule Ref.	Subject	Pro Rule Ref.
RULE #1	PLAYERS-FIELD OBJECTIVE RULE	RULE #1
1-2-5	Playing Field - Distance/Size	1.04
Diagram	Coaches Box - Size	Diagram
1-2-9	Bases - Size	1.06
1-3-2	Bat - Size - Weight - Cupped - ID	1.10
1-3-5	Bat - Illegal	1.10 (c)
1-3-6	Gloves (Catcher - Fielder - Size)	1.12 to 1.15
1-Sec. #4	Uniforms - Should/Should/2 Sets	1.11
1-Sec. #1-#5	Helmet	1.16
1-1-2; 1-1-5; 1-5-5	Head Coach - Removed Helmet - Attachment	No Provisions
1-5-10; 1-5-12; 1-3-3	Head Coach - Jewelry - Weighted Bats	No Provisions
RULE #2	DEFINITIONS	RULE #2
2-4-3	Intentional Walk	No Provisions
2-9-1	Catch	2.00 - Catch
2-10 #1 - #2	Conference	8.06
2-22-1	Obstruction	2.00 - 7.06
2-32 #1 - #2	Slide	6.05 (m)
2-33	Speed-Up - Rule	No Provisions
RULE #3	GAME PRELIMINARIES	RULE #3
3-1-1	Substitutes	3.03 to 3.05
3-1-4	Designated Hitter	6.10
3-3-1	Team Warnings	No Provisions

NFHS Rule Ref.	Subject	Pro Rule Ref.
3-4-1. #2, #3, #4, #5	Conferences	8.06
RULE #4	STARTING/ENDING GAME	RULE #4
4-2-1	Regulation Game	4.10 (a) 4.11; 4.12
4-2-2	Mercy Rule	No Provisions
RULE #5	DEAD BALL – BALL IN PLAY	RULE #5
5-1-1c	Illegal Bat	1.10 (c)
5-1-1f (#5)	Lodged Ball	No Provisions
5-1-1k	Balk/Illegal Pitch	8.0.2 (a) (2 thru 6)
5-1-1m	Malicious Contact	No Provisions
5-1-2e	Remove Helmet	No Provisions
5-1-4	Making Ball Live	5.11
8-29	Interference (offense)	7.08 (b)
RULE #6	PITCHING	RULE #8
3-4-1	Trips to Mound	8.06
6-1-2	Windup Position	8.01 (a) #2
6-1-1 (1-2-3) Pen.	Illegal Pitch	8.01 (d)
6-1-6	Pitching Restrictions	No Provisions
6-2-1e	Going to Mouth	8.02 (a)
6-2-2c	20 sec. Rule	8.04
6-2-2 Except.	Number of warm-ups Allowed	8.03; 8.06
6-2-5	On or Astride Rubber	8.05 (i)
RULE #7	BATTER	RULE #6
7-3-1	Batter Delays	6.02 (c)
7-3-1 Except.	Batter Leaves Box	Same as NFHS
7-4-1a	Illegal Bat	6.06 (d)
7-4-1g; h	Playing Short – Illegal Sub	No Provisions

NFHS Rule Ref.	Subject	Pro Rule Ref.
RULE #8	RUNNER	RULE #7
8-2 Pen.	Appeals	7.10
8-3-2	Obstruction	2.00; 7.06; 7.07
8-3-3c	Awards	7.05 (j)
8-3-3d	Awards	7.04 (c)
8-4-1d	Bat Hitting Ball Twice	6.05 (h)
2-32-2; 8-4-2b	Illegal Slide	6.05 (m)
RULE #10	UMPIRE	RULE #9
3-3-1g4	Arguing Balls/Strikes	9.02 (a)
5-1-1h	Inadvertent Call	No Provisions

Official NFHS Baseball Signals

A. DO NOT PITCH



B. PLAY BALL



C. FOULBALL/TIME OUT/DEAD BALL



D. DELAYED DEAD BALL



E. STRIKE/OUT



F. INFIELD FLY



G. SAFE

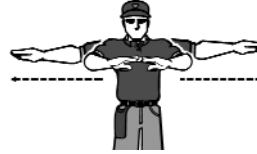

H. FAIR BALL



I. FOUL TIP

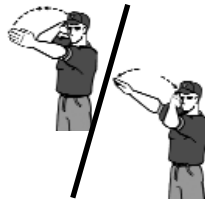

J. COUNT



K. TIME PLAY



- A. Right arm straight out front with palm outward and fingers up — signifies do not pitch, the ball is dead.
 B. Pointing with right hand index finger while facing pitcher — signifies play is to start or be resumed and simultaneously umpire calls "Play."
 C. Both hands open above the head — signifies foulball, time-out or ball is dead immediately.
 D. Left fist extended to the side at shoulder height — signifies an infraction for which (1) the penalty may be ignored or (2) bases may be awarded after no further advance is possible.
 E. Fist up and then out away from body. Coordinate, verbal call, "He's out!" or "Strike!", with the hammering action of the closed fist.
 F. Index finger of right hand is held above the head — signifies infield fly.
 G. Coordinate verbal call, "Safe." Signal also used for dropped balls in the outfield and to determine if a batter's checked swing was legal.
 H. Point toward fair ground with index finger. No verbal call.
 I. The palms of the hands glance off each other as they pass above eye level, followed by a strike call.
 J. Left hand indicates balls followed by the number of strikes thrown on the right hand. Verbally give count.
 K. Place two fingers of the right hand on the left wrist, as if on top of a watch. This signal will only be used in two-out situations where a time play involving a potential run is likely.

National Federation of State
High School Associations



Mission Statement

The National Federation of State High School Associations serves its members, related professional organizations and students by providing leadership for the administration of education-based interscholastic activities, which support academic achievement, good citizenship and equitable opportunities.

We believe:

- the NFHS is the recognized national authority on interscholastic activity programs.
- interscholastic activity programs enrich each student's educational experience.
- participation in education-based activity programs promotes student academic achievement.
- student participation in interscholastic activity programs is a privilege.
- interscholastic participation develops good citizenship and healthy lifestyles.
- interscholastic activity programs foster involvement of a diverse population.
- interscholastic activity programs promote positive school/community relations.
- the NFHS is the pre-eminent authority on competition rules for interscholastic activity programs.
- national competition rules promote fair play and minimize risks for student participants.
- cooperation among state associations advances their individual and collective well-being.
- properly trained administrators/coaches/directors promote the educational mission of the interscholastic experience.
- properly trained officials/judges enhance interscholastic competition.

National Federation of State
High School Associations



Suggested Guidelines for Management of Concussion

A concussion is a traumatic brain injury that interferes with normal brain function. An athlete does not have to lose consciousness (be “knocked out”) to have suffered a concussion.

Common Signs and Symptoms of Concussion Include:

- headache
- fogginess
- difficulty concentrating
- easily confused
- slowed thought processes
- difficulty with memory
- nausea
- lack of energy, tiredness
- dizziness, poor balance
- blurred vision
- sensitive to light and sounds
- mood changes – irritable, anxious or tearful
- appears dazed or stunned
- confused about assignment
- forgets plays
- unsure of game, score or opponent
- moves clumsily
- answers questions slowly
- loses consciousness
- shows behavior or personality changes

Suggested Concussion Management:

1. No athlete should return to play (RTP) or practice on the same day of a concussion.
2. Any athlete suspected of having a concussion should be evaluated by an appropriate health-care professional that day.
3. Any athlete with a concussion should be medically cleared by an appropriate health-care professional prior to resuming participation in any practice or competition.
4. After medical clearance, RTP should follow a step-wise protocol with provisions for delayed RTP based upon return of any signs or symptoms.

For further details please see the “NFHS Suggested Guidelines for Management of Concussion” at www.nfhs.org.

January 2011

National Federation of State
High School Associations



Equipment Guidelines

1. Each NFHS sports rules committee is responsible for recommending the official playing rules to the NFHS Board of Directors for adoption. The committee is not responsible for testing or approving playing equipment for use in interscholastic sports. Equipment manufacturers have undertaken the responsibility for the development of playing equipment that meets the specifications established by the committee. The NFHS urges manufacturers to work with the various independent testing agencies to ensure the production of safe products. Neither the NFHS nor the applicable NFHS sport rules committee certifies the safety of any sport equipment. Only equipment that meets the dimensions and specifications in the NFHS sport rules may be used in interscholastic competition. While the committee does not regulate the development of new equipment and does not set technical or scientific standards for testing equipment, the committee may, from time to time, provide manufacturers with guidance as to the equipment-performance levels it considers consistent with the integrity of the game. The committee reserves the right to intercede to protect and maintain that integrity.

2. Each NFHS sport rules committee suggests that manufacturers planning innovative changes in sports equipment submit the equipment to the applicable NFHS sport rules committee for review before production.

National Federation of State
High School Associations



General Guidelines for Sports Hygiene, Skin Infections and Communicable Diseases

Proper precautions are needed to minimize the potential risk of the spread of communicable disease and skin infections during athletic competition. These conditions include skin infections that occur due to skin contact with competitors and equipment. The transmission of infections such as Methicillin-Resistant Staphylococcus aureus (MRSA) and Herpes Gladiatorum, blood-borne pathogens such as HIV and Hepatitis B, and other infectious diseases such as Influenza can often be greatly reduced through proper hygiene. The NFHS SMAC has outlined and listed below some general guidelines for the prevention of the spread of these diseases.

Universal Hygiene Protocol for All Sports

- Shower immediately after every competition and practice.
- Wash all workout clothing after each practice.
- Wash personal gear (knee pads and braces) weekly.
- Do not share towels or personal hygiene products (razors) with others.
- Refrain from full body (chest, arms, abdomen) cosmetic shaving.

Infectious Skin Diseases

Strategies for reducing the potential exposure to these infectious agents include:

- Athletes must be told to notify a parent or guardian, athletic trainer and coach of any skin lesion prior to any competition or practice. An appropriate health-care professional should evaluate any skin lesion before returning to competition.
- If an outbreak occurs on a team, especially in a contact sport, all team members should be evaluated to help prevent the potential spread of the infection.
- Coaches, officials and appropriate health-care professionals must follow NFHS or state/local guidelines on "time until return to competition." Participation with a covered lesion may be considered if in accordance with NFHS, state or local guidelines and the lesion is no longer contagious.

Blood-Borne Infectious Diseases

Strategies for reducing the potential exposure to these agents include following Universal Precautions such as:

- An athlete who is bleeding, has an open wound, has any amount of blood on his/her uniform, or has blood on his/her person, shall be directed to leave the activity (game or practice) until the bleeding is stopped, the wound is covered, the uniform and/or body is appropriately cleaned, and/or the uniform is changed before returning to activity.
- Athletic trainers or other caregivers need to wear gloves and take other precautions to prevent blood or body fluid-splash from contaminating themselves or others.
- In the event of a blood or body fluid-splash, immediately wash contaminated skin or mucous membranes with soap and water.
- Clean all contaminated surfaces and equipment with disinfectant before returning to competition. Be sure to use gloves when cleaning.
- Any blood exposure or bites to the skin that break the surface must be reported and immediately evaluated by an appropriate health-care professional.

Other Communicable Diseases

Means of reducing the potential exposure to these agents include:

- Appropriate vaccination of athletes, coaches and staff as recommended by the Centers for Disease Control (CDC).
- During times of outbreaks, follow the guidelines set forth by the CDC as well as State and local Health Departments.

For more detailed information, refer to the "Infectious Disease and Blood-borne Pathogens" and "Skin Disorders" sections contained in the NFHS Sports Medicine Handbook.

Revised and Approved in 2010

National Federation of State
High School Associations



Guidelines on Handling Contests During Lightning Disturbances

The purpose of these guidelines is to provide a default policy to those responsible for making decisions concerning the suspension and restarting of contests based on the presence of lightning. The preferred sources from which to request such a policy for your facility would include your state high school association and the nearest office of the National Weather Service.

Proactive Planning

1. Assign staff to monitor local weather conditions before and during events.
2. Develop an evacuation plan, including identification of appropriate nearby shelters.
3. Develop criteria for suspension and resumption of play:
 - a. When thunder is heard, or a cloud-to-ground lightning bolt is seen, the thunderstorm is close enough to strike your location with lightning. Suspend play and take shelter immediately.
 - b. Thirty-minute rule. Once play has been suspended, wait at least 30 minutes after the last thunder is heard or flash of lightning is witnessed prior to resuming play.
 - c. Any subsequent thunder or lightning after the beginning of the 30-minute count, reset the clock and another 30-minute count should begin.
4. Hold periodic reviews for appropriate personnel.

For more detailed information, refer to the "Guidelines for Lightning Safety" contained in the NFHS Sports Medicine Handbook.

Reviewed and Approved in 2010

National Federation of State
High School Associations



Coaches Code of Ethics

The function of a coach is to educate students through participation in interscholastic competition. An interscholastic program should be designed to enhance academic achievement and should never interfere with opportunities for academic success. Each student should be treated with the utmost respect and his or her welfare should be considered in decisions by the coach at all times. Accordingly, the following guidelines for coaches have been adopted by the NFHS Board of Directors.

The coach shall be aware that he or she has a tremendous influence, for either good or ill, on the education of the student and, thus, shall never place the value of winning above the value of instilling the highest ideals of character.

The coach shall uphold the honor and dignity of the profession. In all personal contact with students, officials, athletic directors, school administrators, the state high school athletic association, the media, and the public, the coach shall strive to set an example of the highest ethical and moral conduct.

The coach shall take an active role in the prevention of drug, alcohol and tobacco abuse.

The coach shall avoid the use of alcohol and tobacco products when in contact with players.

The coach shall promote the entire interscholastic program of the school and direct the program in harmony with the total school program.

The coach shall master the contest rules and shall teach them to his or her team members. The coach shall not seek an advantage by circumvention of the spirit or letter of the rules.

The coach shall exert his or her influence to enhance sportsmanship by spectators, both directly and by working closely with cheerleaders, pep club sponsors, booster clubs, and administrators.

The coach shall respect and support contest officials. The coach shall not indulge in conduct which would incite players or spectators against the officials. Public criticism of officials or players is unethical.

The coach should meet and exchange cordial greetings with the opposing coach to set the correct tone for the event before and after the contest.

The coach shall not exert pressure on faculty members to give students special consideration.

The coach shall not scout opponents by any means other than those adopted by the league and/or state high school athletic association.

National Federation of State
High School Associations



Officials Code of Ethics

Officials at an interscholastic athletic event are participants in the educational development of high school students. As such, they must exercise a high level of self-discipline, independence and responsibility. The purpose of this Code is to establish guidelines for ethical standards of conduct for all interscholastic officials.

Officials shall master both the rules of the game and the mechanics necessary to enforce the rules, and shall exercise authority in an impartial, firm and controlled manner.

Officials shall work with each other and their state associations in a constructive and cooperative manner.

Officials shall uphold the honor and dignity of the profession in all interaction with student-athletes, coaches, athletic directors, school administrators, colleagues, and the public.

Officials shall prepare themselves both physically and mentally, shall dress neatly and appropriately, and shall comport themselves in a manner consistent with the high standards of the profession.

Officials shall be punctual and professional in the fulfillment of all contractual obligations.

Officials shall remain mindful that their conduct influences the respect that student-athletes, coaches and the public hold for the profession.

Officials shall, while enforcing the rules of play, remain aware of the inherent risk of injury that competition poses to student-athletes. Where appropriate, they shall inform event management of conditions or situations that appear unreasonably hazardous.

Officials shall take reasonable steps to educate themselves in the recognition of emergency conditions that might arise during the course of competition.

Officials shall maintain an ethical approach while participating in forums, chat rooms and all forms of social media.

Look OFFICIAL
Be OFFICIAL
Get OFFICIAL



at **getofficial.com**

"Located in North Kansas City, MO"



877-438-4242
Order by phone



**toll free Monday - Friday
8am to 5pm CST**

MOST ORDERS SHIPPED THE SAME DAY

COMPLETE UMPIRE STARTER PACKS

Includes Shirt, Pants, Face Mask, Chest Protector,
Leg Guards, Cap, Ball Bag, Indicator and Plate Brush

\$185.95

UNIFORM PACKS

Includes Shirt, Pants, Cap, Ball Bag,
Indicator and Plate Brush

\$85.95

PROTECTION PACKS

Includes Face Mask, Chest
Protector and Leg Guards

\$100.00

ADD AN UMPIRE JACKET TO ANY PACKAGE FOR JUST \$45.00 !!

Visit us online at - www.getofficial.com

Honig's



**WHISTLE
STOP** INC.

P.O. Box 1711
Ann Arbor, MI 48106
800-468-3284

SUPPLIER OF THE FINEST IN
OFFICIALS EQUIPMENT & APPAREL

*We offer the best selection of officiating equipment,
accessories and apparel. For your convenience, log on to our website
for fast, secure shopping any time day or night
www.honigs.com*

For information and a catalog, call

1-800-468-3284

NEW!

-Honig's Colorado-
Englewood, CO
bouwwman-colorado@honigs.com

-Honig's Southwest-
College Station, TX
800-666-7827

-Honig's Southeast-
Ft. Lauderdale, FL
800-955-1754

-Honig's Mid-Atlantic-
Raleigh, NC
800-577-9229

-Honig's New Jersey-
Somerville, NJ
877-466-4465

-Honig's East-
West Suffield, CT
800-351-5474

- Honig's Main Office -
Ann Arbor, MI
888-468.3284

-Honig's West Coast-
Salem, OR
800-867-4327

-Honig's California-
Santa Fe Spgs, CA
800-822-9126

SMITTY

OFFICIAL'S
APPAREL

The "Original SMITTY Lanyard" company has developed a wide range of officiating apparel and accessory products at an affordable price for our dealers and ultimately sports officials.

**SMITTY products feature
fabric with lightweight, moisture management and
quick dry attributes.**

BBS-300
Umpire Shirts



"SMITTY" PRODUCTS ARE
DESIGNED BY ONE OF THE
TOP OFFICIALS IN THE WORLD,
FOR OFFICIALS!

smittyapparel.com
customerservice@smittyapparel.com

BBS-320 Umpire Jacket



Now available in pink
and Carolina blue

Umpire Pants with
Expansion Waistband



The Tools You Need For Today's Game Of Baseball

— Instant Answers 24 Hrs a Day —
at VIDEOUMP.COM

*Preview Videos ... Order DVD's online...
Instant Segment Downloads
Get'em ALL ...At www.videoup.com*

- Rules Made Easy * See a Balk Call a Balk
- * How To Keep Score in Baseball & Softball
- * Handle It! * Don't Show Me Up
- * Pop Up Video Umpire Clinic... and much More!!

*"From Little League to the Big Leagues...
Videoup.com settles the argument"*





Rules That Work as Hard as You Do

AMERICA'S BEST SELLING RULE SUPPLEMENTS

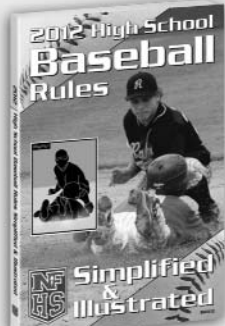

COMPLETE
FOR 2012

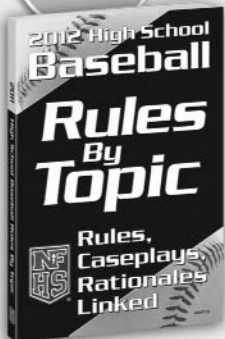

2012 High School Baseball Rules Simplified & Illustrated

Let's face it, not everyone learns as much as they could from reading alone. That's where *Simplified & Illustrated* comes in. Detailed PlayPic[®] and MechaniGram[®] graphics from *Referee Magazine* take the rules and break them down visually, including the most complex. Don't just read the rules, SEE the rules.

Includes:

- New and revised rules for 2012
- Updated points of emphasis
- Quick reference signal chart
- And more

Item Code: BBSSI12
Price: \$8.95

Size: 5 1/2" x 8 1/2"
Approx. 190 pages

2012 High School Baseball Rules By Topic

There are a lot of official rules for High School baseball. Learning them well can be a daunting task to say the least. To simplify the process, *Rules by Topic* takes the official rules and puts them in logical categories. Definitions and references are linked and found in one location – perfect for rules study and open-book exams.

Includes:

- Related case plays
- Rationales and historical tidbits
- Rules book fundamentals
- And more

Item Code: BBSRBT12
Price: \$8.95

Size: 5 1/2" x 8 1/2"
Approx. 230 pages

Order Today! Association Discounts Available



www.referee.com/NFHS/BS • 800-733-6100

Association Discounts Available – Call for Information
Mention Code: P08NBSR When You Order

National Federation of State
High School Associations



Sportsmanship.

It's up to you.™

AN NFHS PROGRAM

to Improve Sportsmanship in Your School and Community



Sportsmanship. It's up to you.™

ToolKit

Campaign materials delivered electronically for easy implementation

RESOURCE DISC (DVD-ROM):

- Implementation guide (printable PDF file)
- Overview video
- Motivational video
- Posters, student pledge cards, artwork (customize with your school logo) (printable PDF files)
- PSA scripts to read at school/games/events
- Radio PSAs (for use on-air)

PRESENTATION DVD (DVD-VIDEO):

- Full-screen, full-resolution videos
- Overview and implementation video
- Motivational video – for all audiences
- 3 Broadcast PSAs

800-776-3462 or
www.nfhs.com

ORDER TODAY \$19.95

Plus shipping and handling

National Federation of State
High School Associations



2011-12 NFHS Rules Books

Published in 17 sports by the National Federation of State High School Associations, rules books contain the official rules for high school athletic competition. These books are designed to explain all aspects of the game or contest. They are good for participants as well as coaches and contest officials.

The NFHS also publishes case books, manuals, handbooks and illustrated books in several sports to help in further explaining the rules.



For ordering information, contact:

NATIONAL FEDERATION OF STATE HIGH SCHOOL ASSOCIATIONS

Customer Service Department

PO Box 361246 Indianapolis, IN 46236-5324

1-800-776-3462

or order online at www.nfhs.com

National Federation of State
High School Associations



Baseball Scorebooks

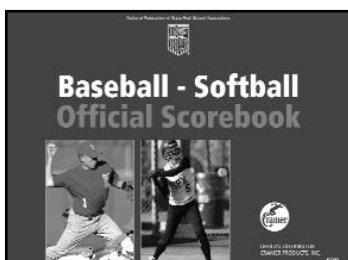

Scorebooks are offered in baseball/softball, basketball, cross country, field hockey, gymnastics, soccer, swimming and diving, track and field, volleyball and wrestling at a cost of \$11.20 each, plus shipping and handling.

To order, contact:

NATIONAL FEDERATION OF STATE HIGH SCHOOL ASSOCIATIONS

Customer Service Department

PO Box 361246

Indianapolis, IN 46236-5324

1-800-776-3462

or order online at www.nfhs.com

National Federation of State
High School Associations



NFHS Statisticians' Manual

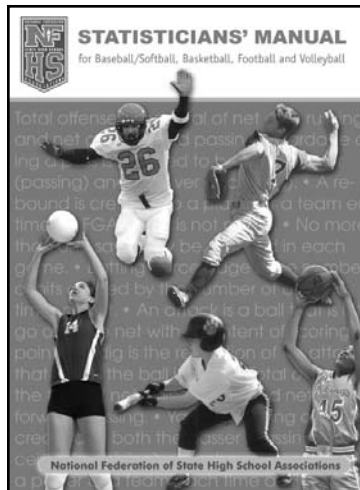

A must for anyone who keeps track of individual and team high school statistics for football, basketball, baseball/softball and volleyball.

Price: \$6.75 plus shipping and handling.

To order, contact:
**NATIONAL FEDERATION OF
STATE HIGH SCHOOL
ASSOCIATIONS**

Customer Service Department
PO Box 361246
Indianapolis, IN 46236

1-800-776-3462

or order online at www.nfhs.com

National Federation of State
High School Associations



Success Starts When Students Take Part.



At the National Federation of State High School Associations (NFHS), we help high school students succeed in school and in their lives, by encouraging participation in athletics and activities, and by improving the participation experience. Visit us at www.nfhs.org.

Take Part. Get Set for Life.™

National Federation of State
High School Associations



Play Now. Win Later.



Participation in high school sports helps students succeed in their lives. More than 7.6 million high school students are enjoying the many benefits of participating in athletic programs.

Take Part. Get Set for Life.™

National Federation of State
High School Associations



The Case for High School Activities



High School Activity Programs:

- Support the Academic Mission of Schools
- Provide Valuable Lessons for Practical Situations
- Foster Success in Later Life

To view "The Case for High School Activities," visit the NFHS Web site at www.nfhs.org.

Take Part. Get Set for Life.™

NFHS PUBLICATIONS

Prices effective April 1, 2011 — March 31, 2012



RULES PUBLICATIONS

Baseball Rules Book	\$7.20	Boys Gymnastics Rules on CD (2011-13)	\$10.00
Baseball Case Book	\$7.20	Girls Gymnastics Rules Book & Manual (2010-12) ..	\$7.20
Baseball Umpires Manual (2011 & 2012)	\$7.20	Ice Hockey Rules Book	\$7.20
Baseball Simplified & Illustrated Rules	\$8.95	Boys Lacrosse Rules Book	\$7.20
Baseball Rules by Topic	\$8.95	Soccer Rules Book	\$7.20
Basketball Rules Book	\$7.20	Softball Rules Book	\$7.20
Basketball Case Book	\$7.20	Softball Case Book	\$7.20
Basketball Simplified & Illustrated Rules	\$8.95	Softball Umpires Manual (2012 & 2013)	\$7.20
Basketball Officials Manual (2011-13)	\$7.20	Spirit Rules Book	\$7.20
Basketball Handbook (2010-12)	\$7.20	Swimming, Diving & Water Polo Rules Book	\$7.20
Basketball Rules by Topic	\$8.95	Track & Field Rules Book	\$7.20
Field Hockey Rules Book	\$7.20	Track & Field Case Book	\$7.20
Football Rules Book	\$7.20	Track & Field Manual (2011 & 2012)	\$7.20
Football Case Book	\$7.20	Volleyball Rules Book	\$7.20
Football Simplified & Illustrated Rules	\$8.95	Volleyball Case Book & Manual	\$7.20
Football Handbook (2011 & 2012)	\$7.20	Wrestling Rules Book	\$7.20
Football Officials Manual (2010 & 2011)	\$7.20	Wrestling Case Book & Manual	\$7.20
Football Rules by Topic	\$8.95		

MISCELLANEOUS ITEMS

NFHS Statisticians' Manual	\$6.75
Scorebooks: Baseball-Softball, Basketball, Swimming & Diving, Cross Country, Soccer, Track & Field, Gymnastics, Volleyball, Wrestling and Field Hockey	\$11.20
Diving Scoresheets (pad of 100)	\$7.25
Volleyball Team Rosters & Lineup Sheets (pads of 100)	\$7.25
Libero Tracking Sheet (pads of 50)	\$7.25
Baseball/Softball Lineup Sheets - 3-Part NCR (sets/100)	\$8.75
Wrestling Tournament Match Cards (sets/100)	\$7.25
Flipping Coin	\$5.50
NFHS Pin	\$4.00
Competitors Numbers (Track and Gymnastics – Waterproof, nontearable, black numbers and six colors of backgrounds. Numbers are 1-1000 sold in sets of 100	\$15.00/set
Lane Numbers (1-8), size 4" x 2 1/2"	\$7.25/set

MISCELLANEOUS SPORTS ITEMS

Court and Field Diagram Guide	\$20.20	Sportsmanship. It's Up to You. Toolkit	\$19.95
NFHS Handbook (2010-11)	\$9.00	High School Activities — A Community Investment in America	\$39.95
Let's Make It Official	\$5.00		

2011-12 NFHS ORDER BLANK

Name _____ Phone _____
 School and/or Organization _____
 Address _____

 City State Zip
 (No PO Boxes. If charging order to a credit card please use address on card.)
If address has changed in the last year please fill in old address.

 Street City State Zip

Check one of the following: Visa MasterCard
 Account No. _____ - _____ - _____ Exp. Date _____
 Signature _____
 P.O. # _____ (Order totals \$50 or more)
 (attach P.O.)

Item#	Description	Quantity	Unit Price	Total

SHIPPING & HANDLING CHARGES: If your subtotal is:
 \$10.00 to \$15.00add **\$7.95** \$75.01 to \$100.00 ...add **\$15.95** Subtotal _____
 \$15.01 to \$25.00add **\$9.95** \$100.01 to \$250.00.add **\$18.95** Shipping &
 \$25.01 to \$50.00add **\$10.95** \$250.01 to \$500.00.add **\$21.95** Handling Charge _____
 \$50.01 to \$75.00add **\$12.95** Over \$500.01 add 5% of subtotal
 Second Day = Standard shipping charges plus **\$15.00** **TOTAL** _____
 Overnight = Standard shipping charges plus **\$25.00**
 All shipments to Alaska, Hawaii, Virgin Islands and Canada – add **\$10.00**
 Call for charges outside continental U.S.
 Minimum purchase on each order \$10.00 before shipping charges



Send to: **NFHS CUSTOMER SERVICE**
 PO Box 361246, INDIANAPOLIS, IN 46236-5324
 Phone 800-776-3462, Fax 317.899.7496 or online at www.nfhs.com

ORDERING INFORMATION

PURCHASE ORDERS are welcomed but all orders under \$50 must be prepaid. Purchase orders may be **either faxed or mailed** to our Customer Service office. If you mail a purchase order after it has been faxed to our Customer Service office, please show it as a **confirming order**. All back-ordered items will be billed additional shipping charges. Terms net 30 days per invoice. All delinquent accounts are charged 1.5% finance charges. **PREPAID ORDERS** will be shipped upon receipt of completed order form accompanied by a check or money order. **All orders must include the proper amount for shipping and handling.**

***SHIPMENTS OUTSIDE UNITED STATES OR CANADA:** Please write to NFHS headquarters for a quotation of total charges which will include a \$2.00 surcharge and actual shipping charges. **Payment must be in U.S. dollars.** Please refer to www.nfhs.com to view our Return Policy.

INDEX TO RULES

References are to Rule, Section, Diagram, Article and Item or Note (N)

Abbreviations:	Definition	8-4-2a 2
Player Positions	Runner Leaves	8-4-1g, 8-4-2a
Rule Book Play	Base on Balls:	
Accident to Player or Umpire	Called	8-1-1c, 8-3-1b
	Definition	2-4-2
Announcements:	Intentional	2-4-3, 5-1-3, 8-1-1c
By Umpires	Scoring	9-6-2
Appeals:	Base Runner	See Runner
Improper Batter	Bat:	
Half Swing	Altered	1-3-5
On Runner	Carelessly Thrown	3-3-1b
On Umpire Decision	Deliberately Thrown	3-3-1m
Assists	Broken	7-3-6
At Bat	Illegal	1-3-5, 7-4-1a
Averages	Loose	1-3-7
Awards	On-Deck Devices	1-3-3
	Specification	1-3-2, 3-4
	Thrown	7-3-6
Balk:	Touched by Batted Ball	8-4-1d
Acts Which Result in	Batter:	
6-1-1, 2, 3 Pen, 6-1-4,	Awarded First	8-1-2
6-2-1 Pen, 6-2-4, 6-2-5	Becomes Runner	8-1
Ball dead	Definition	2-7-1
Definition	Delays	6-2-4d N, 7-2-1e, 7-3-1
Improper Batter	Disconcerts Pitcher	3-3-10, 7-3-3
Penalty	Half Swing	10-1-4a
Scoring	Hit by Batted Ball	8-4-2k
Balk:	Hit by Pitch	2-39 Exc, 5-1-1a,
Awarded	7-3-4, 8-1-1d, 9-6-2	
Bases on	Illegal Action	5-1-1b, e, 7-3
Batted	Improper	7-1-1, 7-1-2 Pen
Bounces Out of Play	Interference by	5-1-2a, 7-3-5, 7-3-6, 8-4-2l
Called	Obstructed	8-1-1e
Dead	Out	7-3, 7-4
Dead Ball Table	Position	2-7-2, 7-1-1, 7-3-2
Defined	Strike Out	7-4-1b, d & e, 8-4-1 e & f
Defaced	Batter-Runner	2-7-3, 8-1-1, 8-1-2,
Delayed Dead	8-2-3, 8-2-4, 8-4-1	
Fair	Batter's Box	1-2-5, 2-7-2, 7-3-1, 7-3-2, 7-3-3
Foul	Battery	2-13-4
Hits Batter	Batting Helmet	1-4-5
2-40, 5-1-1a,	Batting Order	1-1-3, 3-1-1, 4-1-3, 7-1
7-3-4, 8-1-1d, 8-3-1a	Batting Out of Order	7-1-1, 7-1-2 Pen
Hits Runner	Bench Conduct	3-3
Hits Umpire	Blood	3-1-6
Illegally Batted	Bunt	2-8, 7-2-1d, 7-4-1e, 8-4-1c, d
In Flight	Casts	1-5-5, 10-1-7
Live	Catch	2-9-1
Official Game Balls	Catcher:	
Passed	Definition	2-9-2
Pitched	Error Not Charged	9-5-5 Exc (b)
Specification	Glove	1-3-6, Diagram 4
Thrown into Stands	Helmet	1-4-8
When in Play	Obstruction	5-1-2b, 8-1-1e, 8-3-1c
Base:	Interference With	7-3-5, 8-4-1a, 8-4-2l
Dislodged	Position	1-1-4
Double	Catcher's Box	1-2-5, 2-9-3, 6-1-1
Home Plate	Coach:	
Missed	Conduct	3-2-3, 3-3-1
Retouch	Equipment Verification	4-1-3a-b
Specification	Number	3-2-1
Touch Requirements	Reporting Subs	3-1-1
Base Coaches	Restrictions	3-3-1
Base Hits		
Base Line:		
Abandoning		

Interference by	3-2-2, 3-2-3	Verification	4-1-3b
Visits Pitcher	3-4-1	Video	3-3-1e, 10-1-5
Conduct, Bench and Field	3-3-1	Errors	2-12, 9-5-5
Conferences:		Extra Base Hit	2-5-3, 9-3-3
Definition (charged)	2-10-1	Fair Ball:	
Defensive	3-4-1, 3-4-3, 10-2-3j	Bounces Out of Play	5-1-1f, 8-3-3c
Delay of Game	6-2-2b	Caught	8-2-2
Offensive	3-4-2	Defined	2-5-1
Pre-game	2-10-2	Hits Runner	5-1-1f, 8-4-2k
Courtesy Runner	See Speed-Up Rules	Right to Advance	8-1-1a
Darkness	4-2-1, 4-2-3	Feint	2-28-5, 6-1-2, 3, 6-2-2c, 6-2-4a, b & f, 8-2-6
Dead Ball	See Ball, Dead	Fielder:	
Dead Ball Line	5-1-1i	Definition	2-13
Defacing Ball	6-2-1, 10-3-1	Errors	9-5-5
Definitions	Rule 2	Falls into Dugout	5-1-1i, 8-3-3d
Deflected Ball:		Intentionally Dropped Ball	8-4-1c
Batted	8-3-3 a thru c	Interfered With	8-4-2g
Pitched	8-3-3d	Obstructs Runner	5-1-2b, 5-1-3, 8-1-1e, 8-3-1c, 8-3-2
Thrown	8-3-3c	Position	1-1-4, 1-1-5
Delay of Game:		Putouts	2-24-2, 9-5-2
By Batter	7-3-1	Record	9-5-1
By Pitcher	6-2-2	Fielder's Choice	2-14, 9-3-2c
Foult	4-4-1a thru d	Field Layout	1-2, 1-5-2
Start	4-1-1	Fly Ball	2-6-2
Designated Hitter	3-1-4	Force Out	2-24-1, 9-1-1 (b) & (d), 9-5-5
Detached Equipment	8-3-3b, c and end	Force Plays	2-29-3, 8-2-7, 8-3-1 b & c, 8-4-2 j & f
Diamond	See Diagram 2	Forfeits	2-15, 2-27-1, 3-3 Pen, 4-2-1, 4-4-1, 10-2-2
Disqualification	See Ejection	Foul Ball:	
Double First Base	1-2-9, p. 66	Bat Hit Second Time	8-4-1d Exc
Double-Ground Rule	8-3-3c	Bunt	2-8-1 N, 7-2-1d
Doubleheaders	4-1-1 N, 4-2-2b	Caught	5-1-1i, 7-4-1d, 8-2-4, 8-4-1b
Double Play:		Definition	2-16-1
Definition	2-29-2	Interference With	7-4-1f
Interference with	8-1-2b, 8-4-1h, 8-4-2g	Not Caught	5-1-1d, 8-2-8 Exc (a)
Scoring	9-5-4	Tip	2-16-2, 8-4-2i
Double Steal	2-34-2	Uncaught	8-2-8 Exc
Earned Runs	9-6-3	Foul Line	1-2-1
Ejection:		Game:	
Coach	3-3-2	Beginning	4-1-5
Defacing Ball	6-2-1 Pen	Called	2-17-2, 4-2-3, 4-3
Delay	6-2-2	Ending	4-2, 4-4
Illegal Sub	3-1-1 Pen	Forfeited	2-15, 2-27-1, 4-4
Improper Conduct	3-3-1 Pen, 4-4-1e	Objective	1-2-1, 1-2-2
Improper Equipment	1-5-9, 10	Protested	1-2-12, 2-17-1, 4-5, 10-2-3i
Ineligible Sub	3-3-1 Pen	Regulation	2-17-1, 4-2
Intentionally Pitching at Batter	6-2-3 Pen	Starting	4-1
Out, Also	7-4-1h	Summary	2-12-2
Removing Helmet	1-5-1, 1-5-1 PEN	Suspended	2-17-3, 4-3-1
Umpire Authority	2-27-1, 10-2-3c, 10-3-1	Tie	4-3-1
Unsportsmanlike Conduct	3-3-1g, 10-3-1	Gloves:	
Equipment:		Illegal	1-5-7, 5-1-2g, 8-3-4
Ball	1-3-1	Loose	1-3-7
Bases	1-2-9	Specification	1-3-6
Bats	1-3-2, 5	Thrown	8-3-3b, 8-3-3c
Casts	1-5-8	Ground Ball	2-6-4
Dangerous	1-5-8, 9	Ground Rules	4-1-2, 10-2-3a
Defective	1-5-6	Helmet	1-4-5, 8, 5-1-2e
Detached	5-1-2b, 8-3-3b & c, 8-3-4	Hit	See Base Hits
Gloves	1-3-7, 1-5-3, 1-5-4	Home Plate	Diagram 2, 1-2-1, 2, 1-2-10
Helmets	1-1-5	Home Run	2-5-3, 4-2-2 N1
Home Plate	1-2-10	Illegally Batted Ball	7-3-2, 7-4-1a
Legality	1-5-10	Illegal Pitch	2-18, 2-27-1, 6-1-3 Pen
Loose	1-3-7	6-2-1 Pen, 6-2-4c, 7-1-2c	
Non-Traditional	1-5-11	Infielder	2-13-1
Pitcher's Plate	1-3-3	Infield Fly	2-19, 5-1-1j Exc, 8-4-1c1, 8-4-2j, 8-4-2k 1 and 2
Rosin Bag	6-2-1 N	Inning/Half Inning	2-20
Throat Protector	1-5-4, 1-1-5	Intentional Base on Balls	2-4-3, 5-1-3, 8-1-1c
Uniforms	1-4-1, 2, 3, 4		

Intentionally Dropped Ball	5-1-1j, 8-4-1c	Preparatory Pitches (Warmups)	6-2-2c Exc
Interference:		Quick Pitch	6-1-1, 6-1-3, 6-2-4c, 6-2-5
Defensive	See Obstruction	Record	9-6
Double Play	8-4-1h, 8-4-2g	Saves	9-6-7
Offensive	2-21-1, 8-2-8	Set Position	6-1-3
Ball Hits Runner	5-1-1f, 8-4-2k	Substitution	3-1-2
Bat Hits Ball Twice	8-4-1d	Take Signs On Rubber	6-1-1
Bat Hits Fielder	7-3-5	Throwing at Batter	6-2-3
Batter Impedes Fielder	5-1-2a, 8-4-1a, 8-4-2g	Throwing to a Base	6-1-3, 6-1-3, 6-1-5, 6-2-4b, e & f
Coach	3-2-2, 3-2-3, 7-4-1f	Windup Position	6-1-2
Offensive Team Hinders	3-2-3, 5-1-2d, 7-4-1f	Winning/Losing	9-6-6
Runner Impedes Fielder	5-1-1e & f, 8-4-1n, 8-4-2, 8-4-2f	Pitching Mound	Diagram 3, 1-2-6, 1-2-7
Runner Impedes Thrown Ball	8-4-2g	Pitching Restriction	6-1-6
Spectator	2-21-3, 5-1-1f & g, 7-4-1d, 8-3-3e	Play	2-29-1
Umpire	2-21-2, 3-3-1f, 5-1-1f, 5-1-2c	Play Ruling	2-29-4
Verbal	2-21-1, 3-3-10, 5-1-2d	Player(s):	
Jewelry	1-5-12, 3-3-1d	Captain	1-1-2
Light Failure	4-2-3	Concussion	3-1-5, 10-2-3k
Line Drive	2-6-3	Conduct	3-2-3, 3-3-1
Line Up Cards	3-1-1, 4-1-3, 7-1-1	Loosening Up to Bat	3-3-3
Logos	1-4-4	Positions	Diagram 1, 1-1-2, 1-1-3, 1-1-4
Losing Pitcher	9-6-6	Required Number	1-1-2, 4-1-3, 4-4-1f Exc, 7-4-1g
Malicious Contact	2-21-1b, 3-3-1n, 8-3-2	Playing Field	1-2, 2-42-1
Media	1-2-3	Points of Emphasis	p. 67-69
Missed Base	9-1-1 (c)	Postponement Responsibility	4-1-1
Mobility Devices:		Pre-Game Procedures	1-5-10, 4-1-3, 10-2-3a
Coaches	3-2-1	Protested Games	1-2-12, 4-5, 10-2-3i
Umpires	10-1-7	Putouts	2-24-2, 9-5-2
Objective	1-1-1	Records	9-2- thru 9-7
Obstruction	2-22, 5-1-2b, 5-1-3, 8-1-1e, 8-3-1c, 8-3-2	Re-entry	3-1-3
Official Scorer	9-2-2, 10-2-3a	Regulation Game	2-17-1, 4-2
On-Deck Circle	1-2-3, 2-23-1	Relief Pitcher	3-1-1, 6-2-2c, 9-6-5
Overrunning/sliding Base	2-25, 8-2-3, 8-2-4, 8-4-2h Exc, 9-4-1 Exc (1)	Removal from Game	See Ejection
Passed Ball		Resuming Play after Dead Ball	5-1-4
Definition	2-26	Restrictions on Players	3-3-1, 3-3-3
Improper Batter	7-1-2 Pen b N	Rule Revisions	p. 2
Leaves Playing Field	8-3-3d	Runner:	
Scoring	9-6-1	Advance	8-1-1, 8-2-5, 8-3-3
Penalties:		Awarded Base	8-3-1, 8-3-2, 8-3-3
Definition	2-27-1	Batter-Runner	8-1-1, 8-1-2, 8-4-1, 8-2-3
Ignored	5-1-2, 6-2 Pen, 8-1-1e, 8-3-3	Courtesy	See Speed Up Rules
Imposed	5-1-3, 8-3-2 N, 8-3-3e	Definition	2-30-2
Percentages	9-7-2	Hit by Batted Ball	2-39, 5-1-1a, 5-2-2, 6-1-5, 8-4-2k
Pitch	2-28-2	Hit by Pitch	2-39, 5-1-1a, 6-1-4
Pitcher:		Interference	5-1-1e, 8-4-1h, 8-4-2g
Ambidextrous	6-1-1	Interference with	See Runner, Obstruction
Balks	6-1-3 Pen (b), 6-1-4, 6-2-4, 6-2-5	Misses Base	8-2-1, 8-2-3 Pen, 8-4-2p, 9-1-1(c)
Becomes Fielder	6-1-5	Obstructed	8-3-2
Changes Field Position	1-1-5, 3-1-2	Out	7-3-5 Pen, 8-4-2
Conferences	2-10-1, 3-4-1, 10-2-3j	Overruns Base	2-25, 8-4-2g Exc, 9-4-1 Exc (1)
Defaces Ball	6-2-1, 10-3-1	Passes Preceding Runner	8-4-2m
Definition	2-28-1	Removes Helmet	5-1-2e
Delay	6-2-2	Retired	2-30-3, 5-1-1c, 8-4-1h, 8-4-2g
Disconcerted	3-3-1o, 5-1-2d, 7-3-3	Retouch	5-2-2, 8-2-1, 8-2-5, 8-2-6, 8-4-2i
Feint	6-1-3, 6-2-2c, 6-2-4a, b & f	Return to Previous Base	8-1-1e N2, 8-2-1, 8-2-6, 8-3-4
Foreign Substance	6-2-1a	Reverse Run Prohibited	8-4-2n
Glove	1-3-5	Running Out of Base Line	8-4-1g, 8-4-2a
Illegal Equipment	1-5-7	Running Start Prohibited	8-4-2o
Illegal Pitch	6-1-3 Pen, 6-2-1 Pen, 6-2-4c, 7-1-2c	Stolen Base	2-34-1
Infractions	6-2-1	Touch Requirements	2-40, 8-2
Legal Pitch	6-1-4	Runs:	
Legal Position	6-1-1, 2, 3	Batted In	9-3-5
Pivot Foot	2-28-6, 6-1-1, 6-1-2, 6-1-3	Definition	2-30-1
Plate	1-2-11	Earned	9-6-3

Scored	9-1-1, 9-1-2	Announces Subs	10-2-3d
Sacrifices	2-31-1, 9-3-4	Calls "Time"	5-2-1, 6-2-4d1, 7-3-1 Pen, 8-2-5 Pen, 10-2-3b
Saves	9-6-7	Charges	3-3-1k
Score Book	1-1-3, 3-3-1i	Chief Umpire	10-2
Score of Game	4-4-2, 10-2-3m	Clerical Authority	10-1-2
Scoring:		Duties & Responsibilities	10-2, 10-3
Batting Record	9-3-1	Field Umpire	10-3
Earned Run Average	9-7-2d	Handles Live Ball	5-1-1h
Fielding Record	9-5	Improper Batter	7-1-2b
Hit	9-3-2, 9-3-3	Inspects Field	10-2-3a
Official Scorer	9-2-2	Interference	2-21-2, 5-1-1e, 5-1-2c
Pitcher's Record	9-6	Judge of Playing Conditions	4-1-1 N, 10-2-3e
Run Batted In	9-3-5	Jurisdiction	10-1-2
Runner Scores	9-1-1	Restrictions	10-1-5, 10-1-7
Sacrifice	9-3-4	Signals	p. 70
Strikeout	9-3-6, 9-6-4	Touched by Batted Ball	2-21-2, 5-1-1f, 6-1-5
Stolen Base	9-4-1	Touched by Thrown Ball	3-2-3, 5-1-1g
Winning & Losing Pitcher	9-6-6	Unconscious Player	3-1-5, 10-2-3k
Scoring Runs	9-1	Uniforms	1-1-5, 1-4
Sliding:		Unsportsmanlike Conduct	3-3-1g, 10-3-1
Illegal	2-32-2	Video Equipment	3-3-1e, 10-1-5
Legal	2-32-1	Visiting Team	4-1-4
Runner is Out	8-4-2	Visits to Pitcher	See Conferences
Spectators:		Walk	See Base on Balls
Interference	2-21-3, 5-1-1g, 7-4-1d, 8-3-3e, 8-4-1b	Warmup Pitches	6-2-2c, Excep.
Speed Up Rules	p. 66	Weather	4-2-1, 4-2-3
Squeeze Play	2-29-5	Wild Pitch:	
Starter, Reentry of	3-1-3	Definition	2-41
State Association Adoption Rules	p. 69	Improper Batter	7-1-2 Pen.
Stolen Base:		Leaves Playing Field	8-3-3d
Definition	2-34-1	Scoring	9-6-1
Improper Batter	7-1-2 Pen.	Wild Throws	8-3-3c, 8-3-3d
Interference During	2-21-1, 2-21-2	Winning Pitcher	9-6-6
Scoring	9-4-1		
Strike:			
Called	6-1-4, 6-2-4d1, 7-2-1, 7-3-1 Pen, 8-1-1d Exc.		
Penalty	2-27-1(f), 7-3-1 Pen		
Swinging	7-2-1b		
Zone	2-35-1, 6-1-4		
Strikeout	2-24-3, 9-6-4		
Substitutes:			
Illegal	2-36-3		
Unreported	2-36-2		
General	2-36-1, 3-1-1, 7-1-1, 10-2-3d		
Pitcher	3-1-2		
Re-entry	3-1-3		
Suspended Games	2-17-3, 4-2-4		
Suspension of Play	5-2		
Tag Out/Play	2-24-4, 8-2-5 Pen Exc, 8-4-2j		
Third Strike:			
Bunted Foul	2-8-1 N, 7-2-1b, 7-4-1e		
Catcher Hindered	8-4-1a		
Caught	7-4-1c, 8-1-1b N, 8-4-1e		
Not Caught	6-1-4, 7-4-1b, 8-4-1e, f & i		
Right to Advance	8-1-1b		
Three-Foot Lane	8-4-1g		
Throw	2-37-1		
Throw Out	2-24-5		
Tie Game	4-3		
Time At Bat	2-39, 9-3-1a		
Time of Pitch	2-28-3, 8-3-5		
Time Out	2-38, 5-2-1		
Touching	2-40		
Triple Play	9-5-4		
Triple Steal	2-34-3		
Umpire:			
Accident	10-1-6		